



COMMONWEALTH OF PENNSYLVANIA
DEPARTMENT OF ENVIRONMENTAL PROTECTION
AIR QUALITY PROGRAM

STATE ONLY SYNTHETIC MINOR OPERATING PERMIT

Issue Date: September 27, 2021 Effective Date: September 27, 2022
Revision Date: September 27, 2022 Expiration Date: September 30, 2026
Revision Type: Amendment

In accordance with the provisions of the Air Pollution Control Act, the Act of January 8, 1960, P.L. 2119, as amended, and 25 Pa. Code Chapter 127, the Owner, [and Operator if noted] (hereinafter referred to as permittee) identified below is authorized by the Department of Environmental Protection (Department) to operate the air emission source(s) more fully described in this permit. This Facility is subject to all terms and conditions specified in this permit. Nothing in this permit relieves the permittee from its obligations to comply with all applicable Federal, State and Local laws and regulations.

The regulatory or statutory authority for each permit condition is set forth in brackets. All terms and conditions in this permit are federally enforceable unless otherwise designated.

State Only Permit No: 07-05027

Synthetic Minor

Federal Tax Id - Plant Code: 46-4350082-2

Owner Information

Name: CURRY RAIL SVC INC
Mailing Address: PO BOX 538
HOLLIDAYSBURG, PA 16648-0538

Plant Information

Plant: CURRY RAIL SVC INC/FRANKSTOWN
Location: 07 Blair County 07911 Frankstown Township
SIC Code: 4789 Trans. & Utilities - Transportation Services, Nec

Responsible Official

Name: ALEXANDRA CREANY
Title: DIR OF EHS
Phone: (814) 224 - 7444 Email:

Permit Contact Person

Name: ALEXANDRA CREANY
Title: DIR OF EHS
Phone: (814) 224 - 7444 Email:

[Signature] WILLIAM R. WEAVER, SOUTH CENTRAL REGION AIR PROGRAM MANAGER



## SECTION A. Table of Contents

### Section A. Facility/Source Identification

Table of Contents  
Site Inventory List

### Section B. General State Only Requirements

- #001 Definitions.
- #002 Operating Permit Duration.
- #003 Permit Renewal.
- #004 Operating Permit Fees under Subchapter I.
- #005 Transfer of Operating Permits.
- #006 Inspection and Entry.
- #007 Compliance Requirements.
- #008 Need to Halt or Reduce Activity Not a Defense.
- #009 Duty to Provide Information.
- #010 Revising an Operating Permit for Cause.
- #011 Operating Permit Modifications
- #012 Severability Clause.
- #013 De Minimis Emission Increases.
- #014 Operational Flexibility.
- #015 Reactivation
- #016 Health Risk-based Emission Standards and Operating Practice Requirements.
- #017 Circumvention.
- #018 Reporting Requirements.
- #019 Sampling, Testing and Monitoring Procedures.
- #020 Recordkeeping.
- #021 Property Rights.
- #022 Alternative Operating Scenarios.
- #023 Reporting
- #024 Report Format

### Section C. Site Level State Only Requirements

- C-I: Restrictions
- C-II: Testing Requirements
- C-III: Monitoring Requirements
- C-IV: Recordkeeping Requirements
- C-V: Reporting Requirements
- C-VI: Work Practice Standards
- C-VII: Additional Requirements
- C-VIII: Compliance Certification
- C-IX: Compliance Schedule

### Section D. Source Level State Only Requirements

- D-I: Restrictions
- D-II: Testing Requirements
- D-III: Monitoring Requirements
- D-IV: Recordkeeping Requirements
- D-V: Reporting Requirements
- D-VI: Work Practice Standards
- D-VII: Additional Requirements

Note: These same sub-sections are repeated for each source!

### Section E. Source Group Restrictions

- E-I: Restrictions



## **SECTION A. Table of Contents**

- E-II: Testing Requirements
- E-III: Monitoring Requirements
- E-IV: Recordkeeping Requirements
- E-V: Reporting Requirements
- E-VI: Work Practice Standards
- E-VII: Additional Requirements

### **Section F. Alternative Operating Scenario(s)**

- F-I: Restrictions
- F-II: Testing Requirements
- F-III: Monitoring Requirements
- F-IV: Recordkeeping Requirements
- F-V: Reporting Requirements
- F-VI: Work Practice Standards
- F-VII: Additional Requirements

### **Section G. Emission Restriction Summary**

### **Section H. Miscellaneous**

**SECTION A. Site Inventory List**

Source ID	Source Name	Capacity/Throughput	Fuel/Material
034	CLAYTON BOILER (14.3 MMBTU/HR)	14.300 MMBTU/HR	
		13.600 MCF/HR	Natural Gas
101	SURFACE COATING - TRACK 4	7.020 MCF/HR	Natural Gas
102	SURFACE COATING - TRACK 3		
104A	JOHN ZINC FLARE (TANK PURGING)		
105	SHOT BLASTING	100.000 Lbs/HR	STEEL GRIT
107	DEGREASING OPERATIONS		
108	MACT SUBPART 6X ACTIVITIES		
109	SURFACE COATING - TRACK 3	4.800 MCF/HR	Natural Gas
C101	SURFACE COATING BOOTH FILTER		
C102	SURFACE COATING BOOTH FILTER		
C104A	JOHN ZINK FLARE TOWER		
C105	SHOT BLAST BAGHOUSE (INTERIOR)		
C105A	SHOT BLAST BAGHOUSE (EXTERIOR)		
C109	DRY FILTERS		
FM001	NATURAL GAS PIPELINE		
FM003	PURGED FLARE FEED		
S034	CLAYTON BOILER STACK		
S101A	SURFACE COATING		
S101B	SURFACE COATING		
S101C	SURFACE COATING		
S101D	SURFACE COATING		
S102A	SURFACE COATING		
S102B	SURFACE COATING		
S102C	SURFACE COATING		
S104A	TANK PURGING		
S105	SHOT BLASTING		
S105A	SHOT BLAST STACK		
S109-1	SURFACE COATING - TRACK 3 STACK		
S109-2	SURFACE COATING - TRACK 3 STACK		
Z101	SURFACE COATING		
Z102	SURFACE COATING FUGITIVE		
Z107	DEGREASING FUGITIVES		
Z108	SOURCE ID 108 WELDING EMISSIONS		

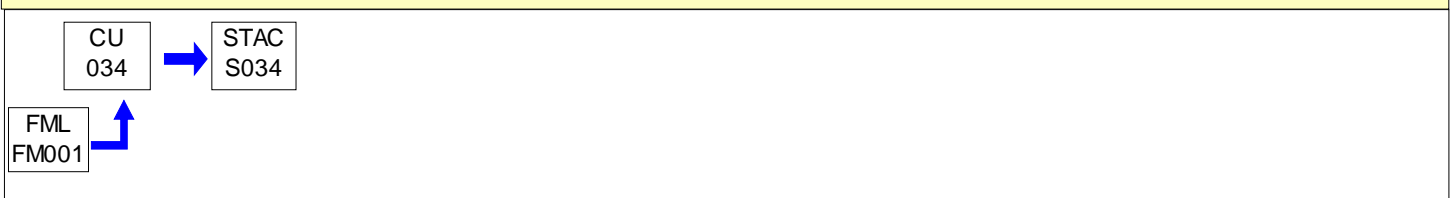
**PERMIT MAPS**



PERMIT MAPS

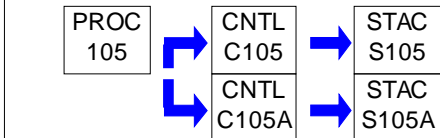
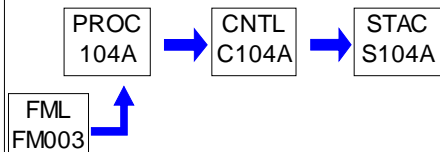
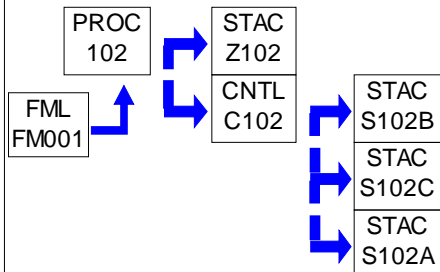
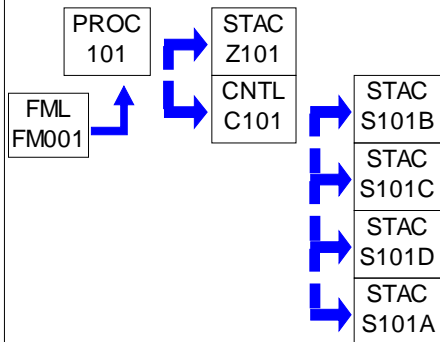



### PERMIT MAPS

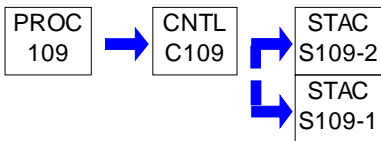
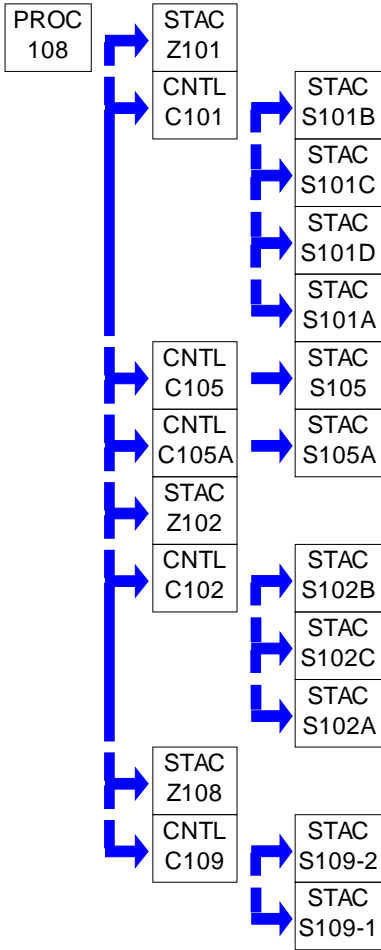

**SECTION B. General State Only Requirements****#001 [25 Pa. Code § 121.1]****Definitions.**

Words and terms that are not otherwise defined in this permit shall have the meanings set forth in Section 3 of the Air Pollution Control Act (35 P.S. § 4003) and in 25 Pa. Code § 121.1.

**#002 [25 Pa. Code § 127.446]****Operating Permit Duration.**

- (a) This operating permit is issued for a fixed term of five (5) years and shall expire on the date specified on Page 1 of this permit.
- (b) The terms and conditions of the expired permit shall automatically continue pending issuance of a new operating permit, provided the permittee has submitted a timely and complete application and paid applicable fees required under 25 Pa. Code Chapter 127, Subchapter I and the Department is unable, through no fault of the permittee, to issue or deny a new permit before the expiration of the previous permit.

**#003 [25 Pa. Code §§ 127.412, 127.413, 127.414, 127.446 & 127.703(b)]****Permit Renewal.**

- (a) The permittee shall submit a timely and complete application for renewal of the operating permit to the appropriate Regional Air Program Manager. The application for renewal of the operating permit shall be submitted at least six (6) months and not more than 18 months before the expiration date of this permit.
- (b) The application for permit renewal shall include the current permit number, a description of any permit revisions that occurred during the permit term, and any applicable requirements that were promulgated and not incorporated into the permit during the permit term. An application is complete if it contains sufficient information to begin processing the application, has the applicable sections completed and has been signed by a responsible official.
- (c) The permittee shall submit with the renewal application a fee for the processing of the application as specified in 25 Pa. Code § 127.703(b). The fees shall be made payable to "The Commonwealth of Pennsylvania Clean Air Fund" and submitted with the fee form to the respective regional office.
- (d) The renewal application shall also include submission of proof that the local municipality and county, in which the facility is located, have been notified in accordance with 25 Pa. Code § 127.413.
- (e) The application for renewal of the operating permit shall also include submission of supplemental compliance review forms in accordance with the requirements of 25 Pa. Code § 127.412(b) and § 127.412(j).
- (f) The permittee, upon becoming aware that any relevant facts were omitted or incorrect information was submitted in the permit application, shall promptly submit such supplementary facts or corrected information as necessary to address any requirements that become applicable to the source after the permittee submits a complete application, but prior to the date the Department takes action on the permit application.

**#004 [25 Pa. Code § 127.703]****Operating Permit Fees under Subchapter I.**

- (a) The permittee shall pay the annual operating permit maintenance fee according to the following fee schedule in either paragraph (1) or (2) in accordance with 25 Pa. Code § 127.703(d) on or before December 31 of each year for the next calendar year.
- (1) For a synthetic minor facility, a fee equal to:
- (i) Four thousand dollars (\$4,000) for calendar years 2021—2025.
  - (ii) Five thousand dollars (\$5,000) for calendar years 2026—2030.
  - (iii) Six thousand three hundred dollars (\$6,300) for the calendar years beginning with 2031.

**SECTION B. General State Only Requirements**

(2) For a facility that is not a synthetic minor, a fee equal to:

- (i) Two thousand dollars (\$2,000) for calendar years 2021—2025.
- (ii) Two thousand five hundred dollars (\$2,500) for calendar years 2026—2030.
- (iii) Three thousand one hundred dollars (\$3,100) for the calendar years beginning with 2031.

(b) The applicable fees shall be made payable to "The Commonwealth of Pennsylvania Clean Air Fund" with the permit number clearly indicated and submitted to the respective regional office.

**#005 [25 Pa. Code §§ 127.450 (a)(4) and 127.464]****Transfer of Operating Permits.**

(a) This operating permit may not be transferred to another person, except in cases of transfer-of-ownership that are documented and approved by the Department.

(b) In accordance with 25 Pa. Code § 127.450(a)(4), a change in ownership of the source shall be treated as an administrative amendment if the Department determines that no other change in the permit is required and a written agreement has been submitted to the Department identifying the specific date of the transfer of permit responsibility, coverage and liability between the current and the new permittee and a compliance review form has been submitted to, and the permit transfer has been approved by, the Department.

(c) This operating permit is valid only for those specific sources and the specific source locations described in this permit.

**#006 [25 Pa. Code § 127.441 and 35 P.S. § 4008]****Inspection and Entry.**

(a) Upon presentation of credentials and other documents as may be required by law, the permittee shall allow the Department or authorized representatives of the Department to perform the following:

(1) Enter at reasonable times upon the permittee's premises where a source is located or emissions related activity is conducted, or where records are kept under the conditions of this permit;

(2) Have access to and copy, at reasonable times, any records that are kept under the conditions of this permit;

(3) Inspect at reasonable times, any facilities, equipment including monitoring and air pollution control equipment, practices, or operations regulated or required under this permit;

(4) Sample or monitor, at reasonable times, any substances or parameters, for the purpose of assuring compliance with the permit or applicable requirements as authorized by the Clean Air Act, the Air Pollution Control Act, or the regulations promulgated under the Acts.

(b) Pursuant to 35 P.S. § 4008, no person shall hinder, obstruct, prevent or interfere with the Department or its personnel in the performance of any duty authorized under the Air Pollution Control Act or regulations adopted thereunder including denying the Department access to a source at this facility. Refusal of entry or access may constitute grounds for permit revocation and assessment of criminal and/or civil penalties.

(c) Nothing in this permit condition shall limit the ability of the EPA to inspect or enter the premises of the permittee in accordance with Section 114 or other applicable provisions of the Clean Air Act.

**#007 [25 Pa. Code §§ 127.441 & 127.444]****Compliance Requirements.**

(a) The permittee shall comply with the conditions of this operating permit. Noncompliance with this permit constitutes a violation of the Clean Air Act and the Air Pollution Control Act and is grounds for one or more of the following:



**SECTION B. General State Only Requirements**

- (1) Enforcement action
- (2) Permit termination, revocation and reissuance or modification
- (3) Denial of a permit renewal application

(b) A person may not cause or permit the operation of a source which is subject to 25 Pa. Code Article III unless the source(s) and air cleaning devices identified in the application for the plan approval and operating permit and the plan approval issued for the source is operated and maintained in accordance with specifications in the applications and the conditions in the plan approval and operating permit issued by the Department. A person may not cause or permit the operation of an air contamination source subject to 25 Pa. Code Chapter 127 in a manner inconsistent with good operating practices.

(c) For purposes of Sub-condition (b) of this permit condition, the specifications in applications for plan approvals and operating permits are the physical configurations and engineering design details which the Department determines are essential for the permittee's compliance with the applicable requirements in this State-Only permit. Nothing in this sub-condition shall be construed to create an independent affirmative duty upon the permittee to obtain a predetermination from the Department for physical configuration or engineering design detail changes made by the permittee.

**#008 [25 Pa. Code § 127.441]****Need to Halt or Reduce Activity Not a Defense.**

It shall not be a defense for the permittee in an enforcement action that it was necessary to halt or reduce the permitted activity in order to maintain compliance with the conditions of this permit.

**#009 [25 Pa. Code §§ 127.442(a) & 127.461]****Duty to Provide Information.**

(a) The permittee shall submit reports to the Department containing information the Department may prescribe relative to the operation and maintenance of each source at the facility.

(b) The permittee shall furnish to the Department, in writing, information that the Department may request to determine whether cause exists for modifying, revoking and reissuing, or terminating this permit, or to determine compliance with the permit. Upon request, the permittee shall also furnish to the Department copies of records that the permittee is required to maintain in accordance with this permit.

**#010 [25 Pa. Code § 127.461]****Revising an Operating Permit for Cause.**

This operating permit may be terminated, modified, suspended or revoked and reissued if one or more of the following applies:

- (1) The permittee constructs or operates the source subject to the operating permit so that it is in violation of the Air Pollution Control Act, the Clean Air Act, the regulations thereunder, a plan approval, a permit or in a manner that causes air pollution.
- (2) The permittee fails to properly or adequately maintain or repair an air pollution control device or equipment attached to or otherwise made a part of the source.
- (3) The permittee has failed to submit a report required by the operating permit or an applicable regulation.
- (4) The EPA determines that the permit is not in compliance with the Clean Air Act or the regulations thereunder.

**#011 [25 Pa. Code §§ 127.450, 127.462, 127.465 & 127.703]****Operating Permit Modifications**

(a) The permittee is authorized to make administrative amendments, minor operating permit modifications and significant operating permit modifications, under this permit, as outlined below:

**SECTION B. General State Only Requirements**

(b) Administrative Amendments. The permittee shall submit the application for administrative operating permit amendments (as defined in 25 Pa. Code § 127.450(a)), according to procedures specified in § 127.450 unless precluded by the Clean Air Act or its regulations.

(c) Minor Operating Permit Modifications. The permittee shall submit the application for minor operating permit modifications (as defined 25 Pa. Code § 121.1) in accordance with 25 Pa. Code § 127.462.

(d) Significant Operating Permit Modifications. The permittee shall submit the application for significant operating permit modifications in accordance with 25 Pa. Code § 127.465.

(e) The applicable fees shall be made payable to "The Commonwealth of Pennsylvania Clean Air Fund" with the permit number clearly indicated and submitted to the respective regional office.

**#012 [25 Pa. Code § 127.441]****Severability Clause.**

The provisions of this permit are severable, and if any provision of this permit is determined by a court of competent jurisdiction to be invalid or unenforceable, such a determination will not affect the remaining provisions of this permit.

**#013 [25 Pa. Code § 127.449]****De Minimis Emission Increases.**

(a) This permit authorizes de minimis emission increases in accordance with 25 Pa. Code § 127.449 so long as the permittee provides the Department with seven (7) days prior written notice before commencing any de minimis emissions increase. The written notice shall:

(1) Identify and describe the pollutants that will be emitted as a result of the de minimis emissions increase.

(2) Provide emission rates expressed in tons per year and in terms necessary to establish compliance consistent with any applicable requirement.

(b) The Department may disapprove or condition de minimis emission increases at any time.

(c) Except as provided below in (d), the permittee is authorized to make de minimis emission increases (expressed in tons per year) up to the following amounts without the need for a plan approval or prior issuance of a permit modification:

(1) Four tons of carbon monoxide from a single source during the term of the permit and 20 tons of carbon monoxide at the facility during the term of the permit.

(2) One ton of NO<sub>x</sub> from a single source during the term of the permit and 5 tons of NO<sub>x</sub> at the facility during the term of the permit.

(3) One and six-tenths tons of the oxides of sulfur from a single source during the term of the permit and 8.0 tons of oxides of sulfur at the facility during the term of the permit.

(4) Six-tenths of a ton of PM<sub>10</sub> from a single source during the term of the permit and 3.0 tons of PM<sub>10</sub> at the facility during the term of the permit. This shall include emissions of a pollutant regulated under Section 112 of the Clean Air Act unless precluded by the Clean Air Act, the regulations thereunder or 25 Pa. Code Article III.

(5) One ton of VOCs from a single source during the term of the permit and 5.0 tons of VOCs at the facility during the term of the permit. This shall include emissions of a pollutant regulated under Section 112 of the Clean Air Act unless precluded by the Clean Air Act, the regulations thereunder or 25 Pa. Code Article III.

(6) Other sources and classes of sources determined to be of minor significance by the Department.

(d) In accordance with § 127.14, the permittee is authorized to install the following minor sources without the need for a plan approval or permit modification:

**SECTION B. General State Only Requirements**

(1) Air conditioning or ventilation systems not designed to remove pollutants generated or released from other sources.

(2) Combustion units rated at 2,500,000 or less Btu per hour of heat input.

(3) Combustion units with a rated capacity of less than 10,000,000 Btu per hour heat input fueled by natural gas supplied by a public utility or by commercial fuel oils which are No. 2 or lighter, viscosity less than or equal to 5.82 c St, and which meet the sulfur content requirements of 25 Pa. Code §123.22 (relating to combustion units). For purposes of this permit, commercial fuel oil shall be virgin oil which has no reprocessed, recycled or waste material added.

(4) Space heaters which heat by direct heat transfer.

(5) Laboratory equipment used exclusively for chemical or physical analysis.

(6) Other sources and classes of sources determined to be of minor significance by the Department.

(e) This permit does not authorize de minimis emission increases if the emissions increase would cause one or more of the following:

(1) Increase the emissions of a pollutant regulated under Section 112 of the Clean Air Act except as authorized in Subparagraphs (c)(4) and (5) of this permit condition.

(2) Subject the facility to the prevention of significant deterioration requirements in 25 Pa. Code Chapter 127, Subchapter D and/or the new source review requirements in Subchapter E.

(3) Violate any applicable requirement of this permit, the Air Pollution Control Act, the Clean Air Act, or the regulations promulgated under either of the acts.

(f) Emissions authorized under this permit condition shall be included in the monitoring, recordkeeping and reporting requirements of this permit.

(g) Except for de minimis emission increases, installation of minor sources made pursuant to this permit condition and Plan Approval Exemptions under 25 Pa. Code § 127.14 (relating to exemptions), the permittee is prohibited from making changes or engaging in activities that are not specifically authorized under this permit without first applying for a plan approval. In accordance with § 127.14(b), a plan approval is not required for the construction, modification, reactivation, or installation of the sources creating the de minimis emissions increase.

(h) The permittee may not meet de minimis emission threshold levels by offsetting emission increases or decreases at the same source.

**#014 [25 Pa. Code § 127.3]****Operational Flexibility.**

The permittee is authorized to make changes within the facility in accordance with the regulatory provisions outlined in 25 Pa. Code § 127.3 (relating to operational flexibility) to implement the operational flexibility requirements provisions authorized under Section 6.1(i) of the Air Pollution Control Act and the operational flexibility terms and conditions of this permit. The provisions in 25 Pa. Code Chapter 127 which implement the operational flexibility requirements include the following:

(1) Section 127.14 (relating to exemptions)

(2) Section 127.447 (relating to alternative operating scenarios)

(3) Section 127.448 (relating to emissions trading at facilities with Federally enforceable emissions caps)

(4) Section 127.449 (relating to de minimis emission increases)

(5) Section 127.450 (relating to administrative operating permit amendments)

**SECTION B. General State Only Requirements**

(6) Section 127.462 (relating to minor operating permit modifications)

(7) Subchapter H (relating to general plan approvals and general operating permits)

**#015 [25 Pa. Code § 127.11]****Reactivation**

(a) The permittee may not reactivate a source that has been out of operation or production for at least one year unless the reactivation is conducted in accordance with a plan approval granted by the Department or in accordance with reactivation and maintenance plans developed and approved by the Department in accordance with 25 Pa. Code § 127.11a(a).

(b) A source which has been out of operation or production for more than five (5) years but less than 10 years may be reactivated and will not be considered a new source if the permittee satisfies the conditions specified in 25 Pa. Code § 127.11a(b).

**#016 [25 Pa. Code § 127.36]****Health Risk-based Emission Standards and Operating Practice Requirements.**

(a) When needed to protect public health, welfare and the environment from emissions of hazardous air pollutants from new and existing sources, the permittee shall comply with the health risk-based emission standards or operating practice requirements imposed by the Department, except as precluded by §§ 6.6(d)(2) and (3) of the Air Pollution Control Act [35 P.S. § 4006.6(d)(2) and (3)].

(b) A person challenging a performance or emission standard established by the Department has the burden to demonstrate that performance or emission standard does not meet the requirements of Section 112 of the Clean Air Act.

**#017 [25 Pa. Code § 121.9]****Circumvention.**

No person may permit the use of a device, stack height which exceeds good engineering practice stack height, dispersion technique or other technique which, without resulting in reduction of the total amount of air contaminants emitted, conceals or dilutes an emission of air contaminants which would otherwise be in violation of 25 Pa. Code Article III, except that with prior approval of the Department, the device or technique may be used for control of malodors.

**#018 [25 Pa. Code §§ 127.402(d) & 127.442]****Reporting Requirements.**

(a) The permittee shall comply with the applicable reporting requirements of the Clean Air Act, the regulations thereunder, the Air Pollution Control Act and 25 Pa. Code Article III including Chapters 127, 135 and 139.

(b) The permittee shall submit reports to the Department containing information the Department may prescribe relative to the operation and maintenance of any air contamination source.

(c) Reports, test data, monitoring data, notifications and requests for renewal of the permit shall be submitted to the:

Regional Air Program Manager  
PA Department of Environmental Protection  
(At the address given in the permit transmittal letter, or otherwise notified)

(d) Any records or information including applications, forms, or reports submitted pursuant to this permit condition shall contain a certification by a responsible official as to truth, accuracy and completeness. The certifications submitted under this permit shall require a responsible official of the facility to certify that based on information and belief formed after reasonable inquiry, the statements and information in the documents are true, accurate and complete.

(e) Any records, reports or information submitted to the Department shall be available to the public except for such

**SECTION B. General State Only Requirements**

records, reports or information which meet the confidentiality requirements of § 4013.2 of the Air Pollution Control Act and §§ 112(d) and 114(c) of the Clean Air Act. The permittee may not request a claim of confidentiality for any emissions data generated for the facility.

**#019 [25 Pa. Code §§ 127.441(c) & 135.5]****Sampling, Testing and Monitoring Procedures.**

(a) The permittee shall comply with the monitoring, recordkeeping or reporting requirements of 25 Pa. Code Chapter 139 and the other applicable requirements of 25 Pa. Code Article III and additional requirements related to monitoring, reporting and recordkeeping required by the Clean Air Act and the regulations thereunder including the Compliance Assurance Monitoring requirements of 40 CFR Part 64, where applicable.

(b) Unless alternative methodology is required by the Clean Air Act and regulations adopted thereunder, sampling, testing and monitoring required by or used by the permittee to demonstrate compliance with any applicable regulation or permit condition shall be conducted in accordance with the requirements of 25 Pa. Code Chapter 139.

**#020 [25 Pa. Code §§ 127.441(c) and 135.5]****Recordkeeping.**

(a) The permittee shall maintain and make available, upon request by the Department, the following records of monitored information:

- (1) The date, place (as defined in the permit) and time of sampling or measurements.
- (2) The dates the analyses were performed.
- (3) The company or entity that performed the analyses.
- (4) The analytical techniques or methods used.
- (5) The results of the analyses.
- (6) The operating conditions as existing at the time of sampling or measurement.

(b) The permittee shall retain records of any required monitoring data and supporting information for at least five (5) years from the date of the monitoring, sample, measurement, report or application. Supporting information includes the calibration data and maintenance records and original strip-chart recordings for continuous monitoring instrumentation, and copies of reports required by the permit.

(c) The permittee shall maintain and make available to the Department upon request, records including computerized records that may be necessary to comply with the reporting, recordkeeping and emission statement requirements in 25 Pa. Code Chapter 135 (relating to reporting of sources). In accordance with 25 Pa. Code Chapter 135, § 135.5, such records may include records of production, fuel usage, maintenance of production or pollution control equipment or other information determined by the Department to be necessary for identification and quantification of potential and actual air contaminant emissions.

**#021 [25 Pa. Code § 127.441(a)]****Property Rights.**

This permit does not convey any property rights of any sort, or any exclusive privileges.

**#022 [25 Pa. Code § 127.447]****Alternative Operating Scenarios.**

The permittee is authorized to make changes at the facility to implement alternative operating scenarios identified in this permit in accordance with 25 Pa. Code § 127.447.

**SECTION B. General State Only Requirements****#023 [25 Pa. Code §135.3]****Reporting**

(a) If the facility is a Synthetic Minor Facility, the permittee shall submit by March 1 of each year an annual emissions report for the preceding calendar year. The report shall include information for all active previously reported sources, new sources which were first operated during the preceding calendar year, and sources modified during the same period which were not previously reported. All air emissions from the facility should be estimated and reported.

(b) A source owner or operator of a Synthetic Minor Facility may request an extension of time from the Department for the filing of an annual emissions report, and the Department may grant the extension for reasonable cause.

**#024 [25 Pa. Code §135.4]****Report Format**

If applicable, the emissions reports shall contain sufficient information to enable the Department to complete its emission inventory. Emissions reports shall be made by the source owner or operator in a format specified by the Department.

**SECTION C. Site Level Requirements****I. RESTRICTIONS.****Emission Restriction(s).****# 001 [25 Pa. Code §123.1]****Prohibition of certain fugitive emissions**

The permittee may not allow the emission into the outdoor atmosphere of a fugitive air contaminant from a source other than the following:

- (1) Construction or demolition of buildings or structures.
- (2) Grading, paving, and maintenance of roads and streets.
- (3) Use of roads and streets. Emissions from material in or on trucks, railroad cars, and other vehicular equipment are not considered as emissions from the use of roads and streets.
- (4) Clearing of land.
- (5) Stockpiling of materials.
- (6) Open burning of materials.
- (7) Sources and classes of sources other than those identified in (1)-(6), above, for which the permittee has obtained a determination from the Department that fugitive emissions from the source, after appropriate control, meet the following requirements:
  - (i) The emissions are of minor significance with respect to causing air pollution; and
  - (ii) The emissions are not preventing or interfering with the attainment or maintenance of any ambient air quality standard.

**# 002 [25 Pa. Code §123.2]****Fugitive particulate matter**

The permittee may not allow the emission of fugitive particulate matter into the outdoor atmosphere from a source specified in Section C, Condition #001, if the emissions are visible at the point the emissions pass outside the permittee's property.

**# 003 [25 Pa. Code §123.31]****Limitations**

The permittee may not allow the emission into the outdoor atmosphere of any malodorous air contaminants from any source in such a manner that the malodors are detectable outside the permittee's property.

**# 004 [25 Pa. Code §123.41]****Limitations**

The permittee may not allow the emission into the outdoor atmosphere of visible air contaminants in such a manner that the opacity of the emission is either of the following:

- (1) Equal to or greater than 20% for a period or periods aggregating more than three (3) minutes in any one hour.
- (2) Equal to or greater than 60% at any time.

**# 005 [25 Pa. Code §123.42]****Exceptions**

The emission limitation of 25 Pa. Code Section 123.41, shall not apply when:

- (1) The presence of uncombined water is the only reason for failure of the emission to meet the limitations.
- (2) The emission results from the operation of equipment used solely to train and test persons in observing the opacity of visible emissions.
- (3) The emission results from sources specified in Section C, Condition #001, (1)-(7).

**SECTION C. Site Level Requirements****# 006 [25 Pa. Code §127.441]****Operating permit terms and conditions.**

The permittee shall limit the facility's annual emission to less than the following thresholds during any consecutive 12-month period:

- (a) 100 tons per year of NO<sub>x</sub>.
- (b) 100 tons per year of carbon monoxide (CO)
- (c) 50 tons per year of volatile organic compounds (VOC)
- (d) 100 tons per year of sulfur oxides (SO<sub>x</sub>) expressed as sulfur dioxide (SO<sub>2</sub>)
- (e) 100 tons per year of PM-10 (particulate matter having an effective aerodynamic diameter less than or equal to a nominal 10 micron body)
- (f) 100 tons/year of PM-2.5 (particulate matter with an aerodynamic diameter of less than or equal to a nominal 2.5 micrometer body as measured by the applicable reference method or an equivalent method)
- (g) 10 tons per year of any individual hazardous air pollutant (HAP)
- (h) 25 tons per year of total combined HAPs

Compliance verification requires emissions to be calculated and recorded for each month and each consecutive 12-month period.

**# 007 [25 Pa. Code §129.14]****Open burning operations**

(a) The permittee may not allow open burning of materials in such a manner that:

- (1) The emissions are visible, at any time, at the point such emissions pass outside the permittee's property.
- (2) Malodorous air contaminants from the open burning are detectable outside the permittee's property.
- (3) The emissions interfere with the reasonable enjoyment of life and property.
- (4) The emissions cause damage to vegetation or property.
- (5) The emissions are or may be deleterious to human or animal health.

(b) Exceptions. The requirements of Subsection (a) do not apply where the open burning operations result from:

- (1) A fire set to prevent or abate a fire hazard, when approved by the Department and set by or under the supervision of a public official.
- (2) Any fire set for the purpose of instructing personnel in fire fighting, when approved by the Department.
- (3) A fire set for the prevention and control of disease or pests, when approved by the Department.
- (4) A fire set solely for recreational or ceremonial purposes.
- (5) A fire set solely for cooking food.

(c) This permit does not constitute authorization to burn solid waste pursuant to section 610 (3) of the Solid Waste Management Act. 35 PS Section 6018.610 (3) or any other provision of the Solid Waste Management Act.

**II. TESTING REQUIREMENTS.****# 008 [25 Pa. Code §127.441]****Operating permit terms and conditions.**

The Department reserves the right to require exhaust stack testing of the sources referenced in this permit to measure emissions for purposes including verification of permit condition compliance and estimation of annual air emissions.



**SECTION C. Site Level Requirements****# 009 [25 Pa. Code §139.1]****Sampling facilities.**

Upon the request of the Department, the permittee shall provide adequate sampling ports, safe sampling platforms and adequate utilities for the performance by the Department of tests on such sources. In the request, the Department will set forth the time period in which the facilities shall be provided as well as the specifications for such facilities.

**# 010 [25 Pa. Code §139.11]****General requirements.**

(a) As specified in 25 Pa. Code Section 139.11(1), performance tests shall be conducted while the source is operating at maximum routine operating conditions or under such other conditions, within the capacity of the equipment, as may be requested by the Department.

(b) As specified in 25 Pa. Code Section 139.11(2), the Department will consider test results for approval where sufficient information is provided to verify the source conditions existing at the time of the test and where adequate data is available to show the manner in which the test was conducted. Information submitted to the Department shall include, at a minimum, all of the following:

- (1) A thorough source description, including a description of any air cleaning devices and the flue.
- (2) Process conditions, for example, the throughput rate of grains, and other conditions which may affect emissions from the process.
- (3) The location of the sampling ports.
- (4) Effluent characteristics, including velocity, temperature, moisture content, gas density (percentage CO, CO<sub>2</sub>, O<sub>2</sub>, and N<sub>2</sub>), static and barometric pressures.
- (5) Sample collection techniques employed, including procedures used, equipment descriptions, and data to verify that isokinetic sampling for particulate matter collection occurred and that acceptable test conditions were met.
- (6) Laboratory procedures and results.
- (7) Calculated results.

**III. MONITORING REQUIREMENTS.****# 011 [25 Pa. Code §123.43]****Measuring techniques**

Visible emissions may be measured using either of the following:

- (1) A device approved by the Department and maintained to provide accurate opacity measurements.
- (2) Observers, trained and certified in EPA Method 9 to measure plume opacity with the naked eye or with the aid of any device(s) approved by the Department.

**# 012 [25 Pa. Code §127.441]****Operating permit terms and conditions.**

The permittee shall conduct a monthly inspection around the plant periphery during daylight hours when the plant is in production to detect visible emissions, fugitive particulate matter emissions, and malodorous air contaminants. Monthly inspections are necessary to determine:

- (a) The presence of visible emissions as stated in Section C, Condition #004. Visible emissions may be measured according to the methods specified in Section C, Condition #011. Alternately, plant personnel who observe visible emissions may report the incidence of visible emissions to the Department within two (2) hours of the incident and make arrangements for a certified observer to measure the visible emissions.
- (b) The presence of fugitive particulate matter emissions beyond the plant property boundaries, as stated in Section C, Condition #002.

**SECTION C. Site Level Requirements**

(c) The presence of malodorous air contaminants beyond the plant property boundaries, as stated in Section C, Condition #003.

**IV. RECORDKEEPING REQUIREMENTS.****# 013 [25 Pa. Code §127.441]****Operating permit terms and conditions.**

The permittee shall maintain records of the monthly inspections referenced in Section C, Condition #012. The records shall include, at a minimum, the following information:

- (1) The name of the company representative monitoring these instances.
- (2) A description of the emissions and/or malodors observed and actions taken to mitigate them.
- (3) The date and time of the observation.
- (4) The wind direction during each observation.

The permittee shall retain these records for a minimum of five (5) years. The records shall be made available to the Department upon its request.

**# 014 [25 Pa. Code §135.5]****Recordkeeping**

The permittee shall maintain and make available upon request by the Department, records including computerized records that may be necessary to comply with 25 Pa. Code Sections 135.3, and 135.21 (relating to reporting, fuel usage, maintenance of production or pollution control equipment or other information determined by the Department to be necessary for identification and quantification of potential and actual air contaminant emissions). If direct recordkeeping is not possible or practical, sufficient records shall be kept to provide the needed information by indirect means.

**V. REPORTING REQUIREMENTS.****# 015 [25 Pa. Code §127.441]****Operating permit terms and conditions.**

The permittee shall report malfunctions which occur at the facility to the Department. A malfunction is any sudden, infrequent, and not reasonably preventable failure of air pollution control equipment, process equipment, or a process to operate in a normal or usual manner that may result in an increase in air emissions above minor significance. Failures that are caused in part by poor maintenance or careless operation are not malfunctions. Malfunctions shall be reported as follows:

(a) Malfunctions which pose an imminent danger to public health, safety, welfare and the environment, shall be immediately reported to the Department by telephone. The telephone report of such malfunctions shall occur no later than two hours after discovery of the incident. Telephone reports can be made to the Air Quality Program at (814) 946-7294 during normal business hours, or to the Department's Emergency Hotline 866-825-0208 at any time. The Emergency Hotline phone number is changed/updated periodically. The current Emergency Hotline phone number can be found at <https://www.dep.pa.gov/About/Regional/SouthcentralRegion/Pages/default.aspx>.

- (1) The notice shall describe the:
  - (i) name and location of the facility;
  - (ii) nature and cause of the malfunction or breakdown;
  - (iii) time when the malfunction or breakdown was first observed;
  - (iv) expected duration of excess emissions; and
  - (v) estimated rate of emissions.
- (2) The owner or operator shall notify the Department immediately when corrective measures have been accomplished.
- (3) The permittee shall submit a written report of instances of such malfunctions to the department, in writing, within three (3) days of the of the telephone report.
- (4) The owner or operator shall submit reports on the operation and maintenance of the source to the Regional Air

**SECTION C. Site Level Requirements**

Program Manager at such intervals and in such form and detail as may be required by the Department. Information required in the reports may include, but is not limited to, process weight rates, firing rates, hours of operation, and maintenance schedules.

(b) Unless otherwise required by this permit, any other malfunction that is not subject to the reporting requirements of (a) above, shall be reported to the Department, in writing, within five (5) days of discovery of the malfunction.

(c) Malfunctions shall be reported electronically to DEP at the following email address: [jpiptaiii@pa.gov](mailto:jpiptaiii@pa.gov)

**# 016 [25 Pa. Code §135.3]****Reporting**

(a) The permittee shall submit an annual Air Information System (AIMS) report to the Department. The AIMS report for a given calendar year is due no later than March 1 of the following year, and shall be submitted to the Air Quality District Supervisor unless otherwise specified.

(b) The permittee may request an extension of time for the Department for filing of the AIMS report specified in part (a) above, and the Department may grant the extension for reasonable cause.

**VI. WORK PRACTICE REQUIREMENTS.****# 017 [25 Pa. Code §123.1]****Prohibition of certain fugitive emissions**

The permittee shall take all reasonable actions to prevent particulate matter from becoming airborne from any source specified in Section C, Condition #001(1)-(7). These actions shall include, but are not limited to the following:

(1) Use, where possible, of water or chemicals for control of dust in the demolition of buildings or structures, construction operations, the grading of roads, or the clearing of land.

(2) Application of asphalt, oil, water, or suitable chemicals on dirt roads, material stockpiles, and other surfaces which may give rise to airborne dusts.

(3) Paving and maintenance of roadways.

(4) Prompt removal of earth or other material from paved streets onto which earth or other material has been transported by trucking or earth moving equipment, erosion by water, or other means.

**# 018 [25 Pa. Code §127.444]****Compliance requirements.**

The permittee shall operate and maintain all sources and any air cleaning devices identified in this operating permit in accordance with the manufacturer's recommendations/specifications, as well as in a manner consistent with good operating practices.

**VII. ADDITIONAL REQUIREMENTS.**

No additional requirements exist except as provided in other sections of this permit including Section B (State Only General Requirements).

**VIII. COMPLIANCE CERTIFICATION.**

No additional compliance certifications exist except as provided in other sections of this permit including Section B (relating to State Only General Requirements).

**IX. COMPLIANCE SCHEDULE.**

No compliance milestones exist.

**SECTION D. Source Level Requirements**

Source ID: 034

Source Name: CLAYTON BOILER (14.3 MMBTU/HR)

Source Capacity/Throughput: 14.300 MMBTU/HR

13.600 MCF/HR

Natural Gas

Conditions for this source occur in the following groups: GROUP 3

**I. RESTRICTIONS.****Emission Restriction(s).****# 001 [25 Pa. Code §123.11]****Combustion units**

The permittee shall not allow the emission of particulate matter into the outdoor atmosphere from the Source 034 boiler in excess of 0.4 pound per million BTU of heat input.

**# 002 [25 Pa. Code §127.441]****Operating permit terms and conditions.**

[Additional authority for this permit condition is also derived from Operating Permit No. GP1-07-05027A]

The permittee shall not allow the emission of CO into the outdoor atmosphere from the Source 034 boiler in excess of 300 ppmvd (corrected to 3% oxygen).

**# 003 [25 Pa. Code §127.441]****Operating permit terms and conditions.**

[Additional authority for this permit condition is also derived from Operating Permit No. GP1-07-05027A]

The permittee shall not allow the emission of NOx into the outdoor atmosphere from the Source 034 boiler in excess of 30 ppmvd (corrected to 3% oxygen).

**Fuel Restriction(s).****# 004 [25 Pa. Code §127.441]****Operating permit terms and conditions.**

[Additional authority for this permit condition is also derived from Operating Permit No. GP1-07-05027A]

The permittee shall operate the Source ID 034 boiler using natural gas only.

**II. TESTING REQUIREMENTS.**

No additional testing requirements exist except as provided in other sections of this permit including Section B (State Only General Requirements) and/or Section E (Source Group Restrictions).

**III. MONITORING REQUIREMENTS.****# 005 [25 Pa. Code §127.441]****Operating permit terms and conditions.**

[Additional authority for this permit condition is also derived from Operating Permit No. GP1-07-05027A]

**SECTION D. Source Level Requirements**

The permittee shall install and maintain the necessary meter(s) to determine and to record amount of fuel usage.

**IV. RECORDKEEPING REQUIREMENTS.**

No additional record keeping requirements exist except as provided in other sections of this permit including Section B (State Only General Requirements) and/or Section E (Source Group Restrictions).

**V. REPORTING REQUIREMENTS.**

No additional reporting requirements exist except as provided in other sections of this permit including Section B (State Only General Requirements) and/or Section E (Source Group Restrictions).

**VI. WORK PRACTICE REQUIREMENTS.**

No additional work practice requirements exist except as provided in other sections of this permit including Section B (State Only General Requirements) and/or Section E (Source Group Restrictions).

**VII. ADDITIONAL REQUIREMENTS.**

No additional requirements exist except as provided in other sections of this permit including Section B (State Only General Requirements) and/or Section E (Source Group Restrictions).

**SECTION D. Source Level Requirements**

Source ID: 101

Source Name: SURFACE COATING - TRACK 4

Source Capacity/Throughput:

7.020 MCF/HR

Natural Gas

Conditions for this source occur in the following groups: GROUP 1  
GROUP 2  
GROUP 4

**I. RESTRICTIONS.**

No additional requirements exist except as provided in other sections of this permit including Section B (State Only General Requirements) and/or Section E (Source Group Restrictions).

**II. TESTING REQUIREMENTS.**

No additional testing requirements exist except as provided in other sections of this permit including Section B (State Only General Requirements) and/or Section E (Source Group Restrictions).

**III. MONITORING REQUIREMENTS.**

No additional monitoring requirements exist except as provided in other sections of this permit including Section B (State Only General Requirements) and/or Section E (Source Group Restrictions).

**IV. RECORDKEEPING REQUIREMENTS.**

No additional record keeping requirements exist except as provided in other sections of this permit including Section B (State Only General Requirements) and/or Section E (Source Group Restrictions).

**V. REPORTING REQUIREMENTS.**

No additional reporting requirements exist except as provided in other sections of this permit including Section B (State Only General Requirements) and/or Section E (Source Group Restrictions).

**VI. WORK PRACTICE REQUIREMENTS.**

No additional work practice requirements exist except as provided in other sections of this permit including Section B (State Only General Requirements) and/or Section E (Source Group Restrictions).

**SECTION D. Source Level Requirements****VII. ADDITIONAL REQUIREMENTS.**

No additional requirements exist except as provided in other sections of this permit including Section B (State Only General Requirements) and/or Section E (Source Group Restrictions).

**SECTION D. Source Level Requirements**

Source ID: 102

Source Name: SURFACE COATING - TRACK 3

Source Capacity/Throughput:

Conditions for this source occur in the following groups: GROUP 1  
GROUP 2  
GROUP 4

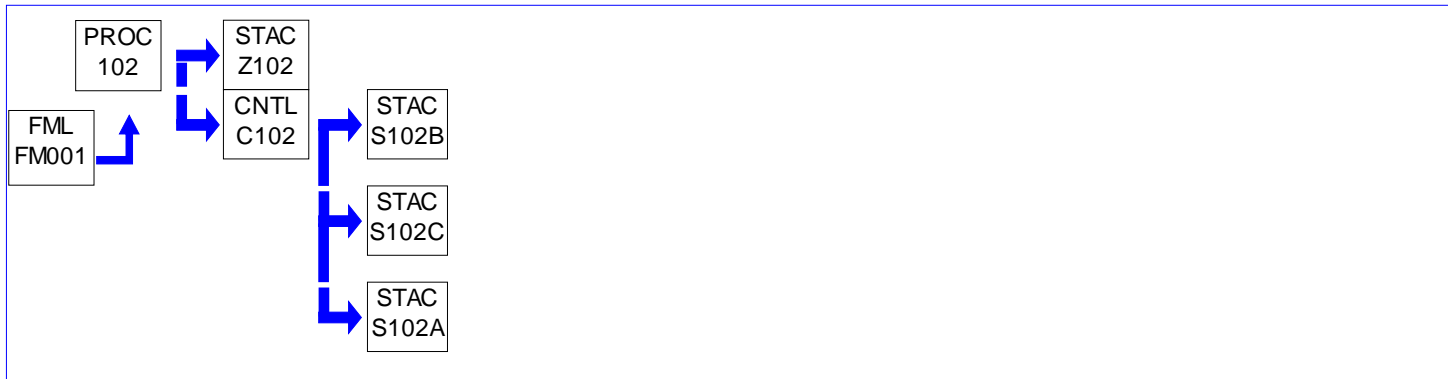
**I. RESTRICTIONS.**

No additional requirements exist except as provided in other sections of this permit including Section B (State Only General Requirements) and/or Section E (Source Group Restrictions).

**II. TESTING REQUIREMENTS.**

No additional testing requirements exist except as provided in other sections of this permit including Section B (State Only General Requirements) and/or Section E (Source Group Restrictions).

**III. MONITORING REQUIREMENTS.**

No additional monitoring requirements exist except as provided in other sections of this permit including Section B (State Only General Requirements) and/or Section E (Source Group Restrictions).

**IV. RECORDKEEPING REQUIREMENTS.**

No additional record keeping requirements exist except as provided in other sections of this permit including Section B (State Only General Requirements) and/or Section E (Source Group Restrictions).

**V. REPORTING REQUIREMENTS.**

No additional reporting requirements exist except as provided in other sections of this permit including Section B (State Only General Requirements) and/or Section E (Source Group Restrictions).

**VI. WORK PRACTICE REQUIREMENTS.**

No additional work practice requirements exist except as provided in other sections of this permit including Section B (State Only General Requirements) and/or Section E (Source Group Restrictions).

**VII. ADDITIONAL REQUIREMENTS.**

No additional requirements exist except as provided in other sections of this permit including Section B (State Only General Requirements) and/or Section E (Source Group Restrictions).



**SECTION D. Source Level Requirements**

Source ID: 104A

Source Name: JOHN ZINC FLARE (TANK PURGING)

Source Capacity/Throughput:

**I. RESTRICTIONS.****Emission Restriction(s).**

# 001 [25 Pa. Code §123.13]

**Processes**

The permittee may not permit the emission into the outdoor atmosphere of particulate matter (PM) from the rail car purging operations in a manner that the concentration of PM in the effluent gas exceeds 0.04 grains per dry standard cubic foot.

**II. TESTING REQUIREMENTS.**

No additional testing requirements exist except as provided in other sections of this permit including Section B (State Only General Requirements).

**III. MONITORING REQUIREMENTS.**

No additional monitoring requirements exist except as provided in other sections of this permit including Section B (State Only General Requirements).

**IV. RECORDKEEPING REQUIREMENTS.**

No additional record keeping requirements exist except as provided in other sections of this permit including Section B (State Only General Requirements).

**V. REPORTING REQUIREMENTS.**

No additional reporting requirements exist except as provided in other sections of this permit including Section B (State Only General Requirements).

**VI. WORK PRACTICE REQUIREMENTS.**

# 002 [25 Pa. Code §127.441]

**Operating permit terms and conditions.**

At no time shall any propane, butane, butadiene (inhibited), butylene, isobutane, isobutylene, propylene, propane propylene (a mixture of propane and propylene) or anhydrous ammonia tank car be evacuated to the atmosphere other than through the flare nor shall an evacuated car ever be opened to the atmosphere unless steam has first been injected into the car and all residual car contents forced into the flare.

[Additional authority for this condition is derived from Operating Permit No. 07-399-005]

# 003 [25 Pa. Code §127.441]

**Operating permit terms and conditions.**

The flare shall not be used to flare residual material from any railroad tank car containing any substance other than propane, butane, butadiene (inhibited), butylene, isobutane, isobutylene, propylene, propane propylene (a mixture of propane and propylene) or anhydrous ammonia.



**SECTION D. Source Level Requirements**

[Additional authority for this condition is derived from Operating Permit No. 07-399-005]

**# 004 [25 Pa. Code §127.441]**  
**Operating permit terms and conditions.**  
 At no time shall any propane, butane, butadiene (inhibited), butylene, isobutane, isobutylene, propylene, propane propylene (a mixture of propane and propylene) or anhydrous ammonia tank car be vented to the flare unless the flare's pilot burner is lit. Additionally, at no time shall any anhydrous ammonia tank car be vented to the flare unless the flare's blower is turned off.

[Additional authority for this condition is derived from Operating Permit No. 07-399-005]

**VII. ADDITIONAL REQUIREMENTS.**

No additional requirements exist except as provided in other sections of this permit including Section B (State Only General Requirements).

**SECTION D. Source Level Requirements**

Source ID: 105

Source Name: SHOT BLASTING

Source Capacity/Throughput: 100.000 Lbs/HR STEEL GRIT

Conditions for this source occur in the following groups: GROUP 4

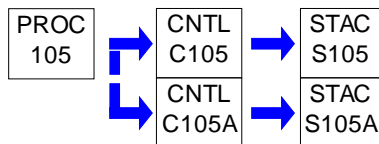
**I. RESTRICTIONS.****Emission Restriction(s).**

# 001 [25 Pa. Code §123.13]

**Processes**

The permittee may not permit the emission into the outdoor atmosphere of particulate matter (PM) from any source in a manner that the particulate matter in the effluent gas exceeds 0.04 grain per dry standard cubic foot.

**II. TESTING REQUIREMENTS.**

No additional testing requirements exist except as provided in other sections of this permit including Section B (State Only General Requirements) and/or Section E (Source Group Restrictions).

**III. MONITORING REQUIREMENTS.**

# 002 [25 Pa. Code §127.441]

**Operating permit terms and conditions.**

The permittee shall conduct a weekly pressure drop reading across the Tenkay baghouse.

# 003 [25 Pa. Code §127.441]

**Operating permit terms and conditions.**

The Tenkay baghouse shall be operated at all times when the shot blast booth is in operation.

# 004 [25 Pa. Code §127.441]

**Operating permit terms and conditions.**

The permittee shall maintain instrumentation to measure and display the pressure differential across the Tenkay baghouse.

# 005 [25 Pa. Code §127.441]

**Operating permit terms and conditions.**

The two (2) shot blast baghouse stacks shall be inspected for visible emissions on a weekly basis when the Shot Blast source is in operation.

The permittee shall retain these records for a minimum of (5) years and shall be made available to the Department upon request.

**IV. RECORDKEEPING REQUIREMENTS.**

# 006 [25 Pa. Code §127.441]

**Operating permit terms and conditions.**

A weekly record shall be maintained of the pressure drop readings and gauge performance.

A maintenance log shall be maintained of all repairs performed on the Tenkay baghouse, including, but not limited to bag change-out.



**SECTION D. Source Level Requirements**

**V. REPORTING REQUIREMENTS.**

No additional reporting requirements exist except as provided in other sections of this permit including Section B (State Only General Requirements) and/or Section E (Source Group Restrictions).

**VI. WORK PRACTICE REQUIREMENTS.**

<p><b># 007 [25 Pa. Code §127.441]</b>  <b>Operating permit terms and conditions.</b>          Operation of any air emission source is contingent upon proper operation of its associated emissions control system, unless otherwise approved by the Department.</p>
<p><b># 008 [25 Pa. Code §127.444]</b>  <b>Compliance requirements.</b>          The permittee shall maintain each source and applicable control device in accordance with the manufacturer's specifications and good operating practices.</p>

**VII. ADDITIONAL REQUIREMENTS.**

No additional requirements exist except as provided in other sections of this permit including Section B (State Only General Requirements) and/or Section E (Source Group Restrictions).

**SECTION D. Source Level Requirements**

Source ID: 107

Source Name: DEGREASING OPERATIONS

Source Capacity/Throughput:

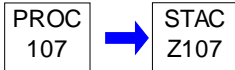
**I. RESTRICTIONS.****Emission Restriction(s).****# 001 [25 Pa. Code §129.63]****Degreasing operations**

Degreasing activities shall be conducted in accordance with the applicable requirements of 25 Pa. Code Section 129.63 to include the following:

The permittee may not use, sell or offer for sale for use in a cold cleaning machine any solvent with a vapor pressure of 1.0 millimeter of mercury (mm Hg) or greater and containing greater than 5% VOC by weight, measured at 20°C (68°F) containing VOCs. This condition does not apply to the following cold cleaning machines:

- (1) Machine used in extreme cleaning service.
- (2) Machines, in which the Department approves in writing, that compliance with this condition will result in unsafe operating conditions.
- (3) To immersion cold cleaning machines with a freeboard ratio equal to or greater than 0.75.

**II. TESTING REQUIREMENTS.**

No additional testing requirements exist except as provided in other sections of this permit including Section B (State Only General Requirements).

**III. MONITORING REQUIREMENTS.**

No additional monitoring requirements exist except as provided in other sections of this permit including Section B (State Only General Requirements).

**IV. RECORDKEEPING REQUIREMENTS.****# 002 [25 Pa. Code §129.63]****Degreasing operations**

The permittee shall maintain the following records:

- (a) The name and address of the solvent supplier.
- (b) The type of solvent including the product or vendor identification number.
- (c) The vapor pressure of the solvent measured in mm Hg at 20°C (68°F).

An invoice, bill of sale, certificate that corresponds to a number of sales, Material Safety Data Sheet (MSDS), or other appropriate documentation acceptable to the Department may be used to comply with this section.

The permittee shall retain these records for a minimum of two (2) years and shall make them available to the Department upon its request.

**SECTION D. Source Level Requirements****V. REPORTING REQUIREMENTS.**

No additional reporting requirements exist except as provided in other sections of this permit including Section B (State Only General Requirements).

**VI. WORK PRACTICE REQUIREMENTS.****# 003 [25 Pa. Code §129.63]****Degreasing operations**

Immersion cold cleaning machines shall have a freeboard ratio of 0.50 or greater.

**# 004 [25 Pa. Code §129.63]****Degreasing operations**

The permittee shall operate the degreasers in accordance with the following procedures:

- (a) Waste solvent shall be collected and stored in closed containers. The closed containers may contain a device that allows pressure relief, but does not allow liquid solvent to drain from the container.
- (b) Flushing of parts using a flexible hose or other flushing device shall be performed only within the unit. The solvent spray shall be a solid fluid stream, not an atomized or shower spray.
- (c) Sponges, fabric, wood, leather, paper products and other absorbent materials may not be cleaned in the degreasers.
- (d) Air-agitated solvent baths may not be used.
- (e) Spills during solvent transfer and use of the degreasers shall be cleaned up immediately.

**# 005 [25 Pa. Code §129.63]****Degreasing operations**

The degreasers shall be equipped with one of the following:

- (a) A cover that shall be closed at all times except during cleaning of parts or the addition or removal of solvent.
- (b) A perforated drain with a diameter of not more than six (6) inches, if the unit drains directly into the solvent storage reservoir.

**# 006 [25 Pa. Code §129.63]****Degreasing operations**

The degreasers shall have a permanent, conspicuous label summarizing the operating requirements in Condition #004. In addition, the label shall include the following discretionary good operating practices:

- (a) Cleaned parts should be drained at least 15 seconds or until dripping ceases, whichever is longer. Parts having cavities or blind holes shall be tipped or rotated while the part is draining. During the draining, tipping or rotating, the parts should be positioned so that solvent drains directly back to the unit.
- (b) When a pump-agitated solvent bath is used, the agitator should be operated to produce a rolling motion of the solvent with no observable splashing of the solvent against the tank walls or the parts being cleaned.
- (c) Work area fans should be located and positioned so that they do not blow across the opening of the degreaser unit(s).

**VII. ADDITIONAL REQUIREMENTS.****# 007 [25 Pa. Code §129.63]****Degreasing operations**

The aforementioned permit conditions apply to degreasers so long as the cold cleaning machine uses 2 gallons or more of solvents containing greater than 5% VOC content by weight for the cleaning of metal parts.



**SECTION D. Source Level Requirements**

Source ID: 108

Source Name: MACT SUBPART 6X ACTIVITIES

Source Capacity/Throughput:

Conditions for this source occur in the following groups: GROUP 4

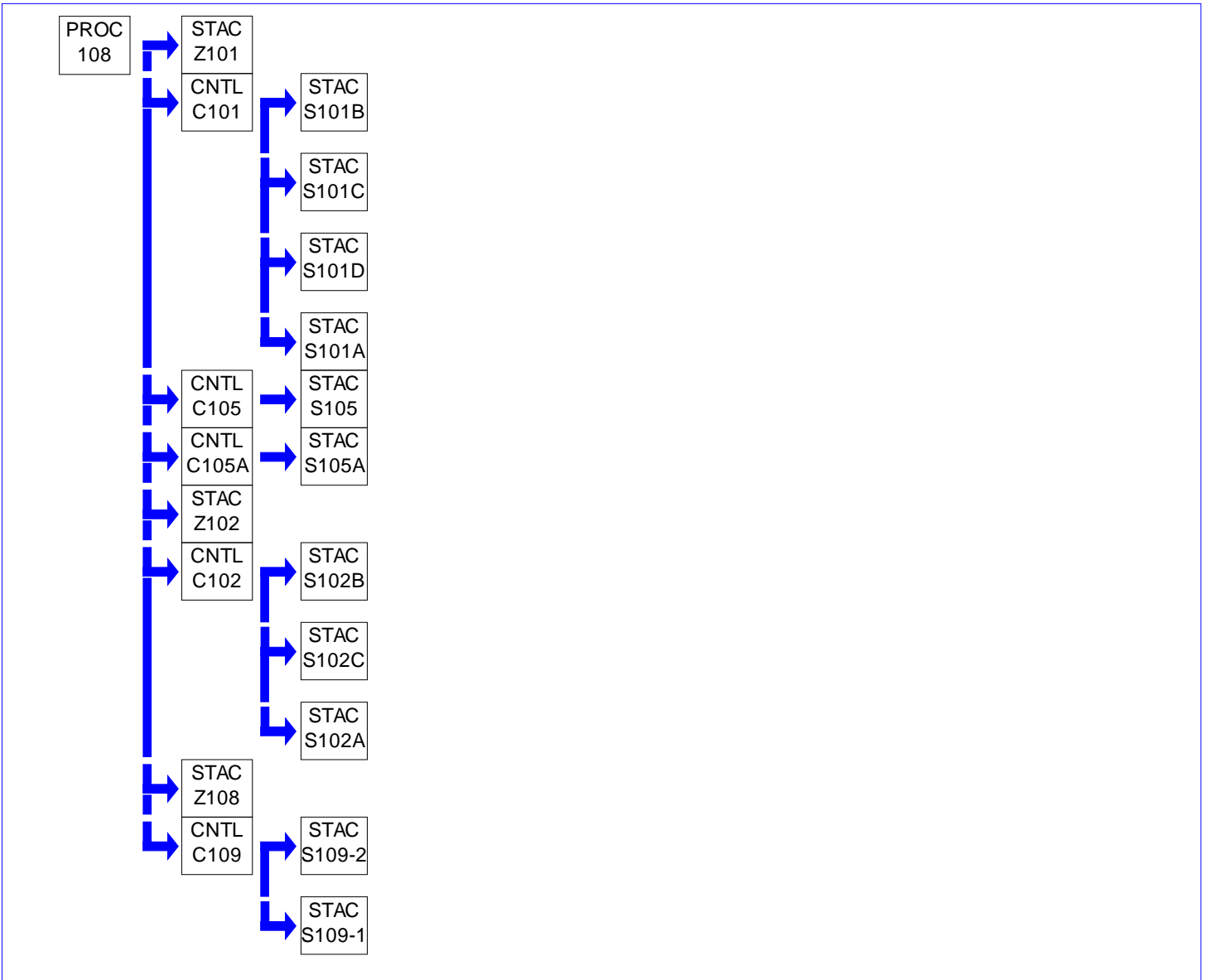



## **SECTION D. Source Level Requirements**

### **I. RESTRICTIONS.**

No additional requirements exist except as provided in other sections of this permit including Section B (State Only General Requirements) and/or Section E (Source Group Restrictions).

### **II. TESTING REQUIREMENTS.**

No additional testing requirements exist except as provided in other sections of this permit including Section B (State Only General Requirements) and/or Section E (Source Group Restrictions).

### **III. MONITORING REQUIREMENTS.**

No additional monitoring requirements exist except as provided in other sections of this permit including Section B (State Only General Requirements) and/or Section E (Source Group Restrictions).

### **IV. RECORDKEEPING REQUIREMENTS.**

No additional record keeping requirements exist except as provided in other sections of this permit including Section B (State Only General Requirements) and/or Section E (Source Group Restrictions).

### **V. REPORTING REQUIREMENTS.**

No additional reporting requirements exist except as provided in other sections of this permit including Section B (State Only General Requirements) and/or Section E (Source Group Restrictions).

### **VI. WORK PRACTICE REQUIREMENTS.**

No additional work practice requirements exist except as provided in other sections of this permit including Section B (State Only General Requirements) and/or Section E (Source Group Restrictions).

### **VII. ADDITIONAL REQUIREMENTS.**

No additional requirements exist except as provided in other sections of this permit including Section B (State Only General Requirements) and/or Section E (Source Group Restrictions).



**SECTION D. Source Level Requirements**

Source ID: 109

Source Name: SURFACE COATING - TRACK 3

Source Capacity/Throughput:

4.800 MCF/HR

Natural Gas

Conditions for this source occur in the following groups: GROUP 1  
GROUP 2  
GROUP 4

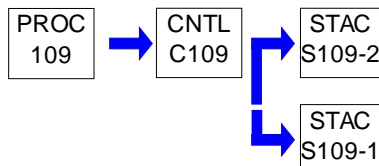
**I. RESTRICTIONS.**

No additional requirements exist except as provided in other sections of this permit including Section B (State Only General Requirements) and/or Section E (Source Group Restrictions).

**II. TESTING REQUIREMENTS.**

No additional testing requirements exist except as provided in other sections of this permit including Section B (State Only General Requirements) and/or Section E (Source Group Restrictions).

**III. MONITORING REQUIREMENTS.**

No additional monitoring requirements exist except as provided in other sections of this permit including Section B (State Only General Requirements) and/or Section E (Source Group Restrictions).

**IV. RECORDKEEPING REQUIREMENTS.****# 001 [25 Pa. Code §127.441]****Operating permit terms and conditions.**

The permittee shall weekly, inspect the paint booth filters and monitor pressure drop readings across the particulate filters of the coating booth, Source ID 109 to assure proper operation in accordance with the manufacturer's requirements.

The permittee shall keep records of pressure drop readings and paint booth filter inspections for the most recent 5-year period and made available to the Department upon request.

**V. REPORTING REQUIREMENTS.**

No additional reporting requirements exist except as provided in other sections of this permit including Section B (State Only General Requirements) and/or Section E (Source Group Restrictions).

**VI. WORK PRACTICE REQUIREMENTS.****# 002 [25 Pa. Code §127.441]****Operating permit terms and conditions.**

The permittee shall not allow the operation of coating booth, Source ID 109 unless it is equipped with dry filters for particulate matter control.

**# 003 [25 Pa. Code §127.441]****Operating permit terms and conditions.**

The coating booth, Source ID 109 shall be equipped with a device to measure the pressure drop across the coating booth

**SECTION D. Source Level Requirements**

filters.

**VII. ADDITIONAL REQUIREMENTS.**

No additional requirements exist except as provided in other sections of this permit including Section B (State Only General Requirements) and/or Section E (Source Group Restrictions).

**SECTION E. Source Group Restrictions.**

Group Name: GROUP 1

Group Description: Surface Coating Operations

Sources included in this group

ID	Name
101	SURFACE COATING - TRACK 4
102	SURFACE COATING - TRACK 3
109	SURFACE COATING - TRACK 3

**I. RESTRICTIONS.****Emission Restriction(s).****# 001 [25 Pa. Code §123.13]****Processes**

The permittee may not allow the emission into the outdoor atmosphere of particulate matter from any source in a manner that the particulate matter in the effluent gas exceeds 0.04 grains per dry standard cubic foot.

**II. TESTING REQUIREMENTS.**

No additional testing requirements exist except as provided in other sections of this permit including Section B (State Only General Requirements).

**III. MONITORING REQUIREMENTS.****# 002 [25 Pa. Code §127.441]****Operating permit terms and conditions.**

The permittee shall demonstrate the VOC/HAP content of each surface coating by one of the following methods:

(a) For surface coatings applied as they are received from the manufacturer, the permittee may demonstrate compliance with the applicable standard by obtaining EPA Method 24 certification testing from the manufacturer, or by maintaining VOC/HAP data sheets from the manufacturer.

(b) In the absence of EPA Method 24 certification testing from the manufacturer, or VOC/HAP data sheets from the manufacturer, allowed under part (a), above, the permittee shall perform EPA Method 24 certification testing on all surface coatings applied as received from the manufacturer.

(c) The permittee may use calculated VOC content values in lieu of EPA Method 24 certification testing for multi-part surface coatings where the permittee maintains VOC/HAP data sheets for all surface coating constituents (i.e. coatings, pigments, thinners/cutting solvents), and also maintains documentation from the manufacturer as to the recommended mix ratio of the parts. In the event of any inconsistency between the calculated VOC content and data obtained from EPA Method 24 certification testing, the latter shall take precedence.

**IV. RECORDKEEPING REQUIREMENTS.****# 003 [25 Pa. Code §129.52]****Surface coating processes**

The company shall maintain detailed records which shall include as a minimum the following:

- (a) The facility shall maintain daily records of:
- (1) Coating, thinner or component name and identification
  - (2) The volume used
  - (3) The mix ratio
  - (4) Pounds of VOC per gallon of solids (as applied)
  - (5) Coating density in pounds per gallon
  - (6) Weight percent of total volatiles (100%-weight percent solids)
  - (7) Weight percent of water
  - (8) Weight percent of exempt solvents
  - (9) Weight percent of solids
  - (10) Volume percent of solids

**SECTION E. Source Group Restrictions.**

(b) The VOC content of each coating, thinner and other component as supplied.

(c) The VOC content of each as applied coating.

All records shall be maintained for 5 years and shall be made available to the Department upon request.

**V. REPORTING REQUIREMENTS.**

No additional reporting requirements exist except as provided in other sections of this permit including Section B (State Only General Requirements).

**VI. WORK PRACTICE REQUIREMENTS.**

No additional work practice requirements exist except as provided in other sections of this permit including Section B (State Only General Requirements).

**VII. ADDITIONAL REQUIREMENTS.**

No additional requirements exist except as provided in other sections of this permit including Section B (State Only General Requirements).

**SECTION E. Source Group Restrictions.**

Group Name: GROUP 2

Group Description: 25 Pa. Code, Section 129.52d Requirements

**Sources included in this group**

ID	Name
101	SURFACE COATING - TRACK 4
102	SURFACE COATING - TRACK 3
109	SURFACE COATING - TRACK 3

**I. RESTRICTIONS.**

No additional requirements exist except as provided in other sections of this permit including Section B (State Only General Requirements).

**II. TESTING REQUIREMENTS.**

No additional testing requirements exist except as provided in other sections of this permit including Section B (State Only General Requirements).

**III. MONITORING REQUIREMENTS.**

No additional monitoring requirements exist except as provided in other sections of this permit including Section B (State Only General Requirements).

**IV. RECORDKEEPING REQUIREMENTS.**

No additional record keeping requirements exist except as provided in other sections of this permit including Section B (State Only General Requirements).

**V. REPORTING REQUIREMENTS.**

No additional reporting requirements exist except as provided in other sections of this permit including Section B (State Only General Requirements).

**VI. WORK PRACTICE REQUIREMENTS.**

No additional work practice requirements exist except as provided in other sections of this permit including Section B (State Only General Requirements).

**VII. ADDITIONAL REQUIREMENTS.****# 001 [25 Pa. Code §127.441]****Operating permit terms and conditions.**

§ 129.52d. Control of VOC emissions from miscellaneous metal parts surface coating processes, miscellaneous plastic parts surface coating processes and pleasure craft surface coatings.

(a) Applicability.

(1) This section applies to the owner and operator of a miscellaneous metal part surface coating process or miscellaneous plastic part surface coating process, or both, if the total actual VOC emissions from all miscellaneous metal part coating units and miscellaneous plastic part coating units, including related cleaning activities, at the facility are equal to or greater than 2.7 tons per 12-month rolling period, before consideration of controls.

(2) This section applies, as specified, to the owner and operator of a miscellaneous metal part surface coating process or miscellaneous plastic part surface coating process, or both, if the total actual VOC emissions from all miscellaneous metal part coating units and miscellaneous plastic part coating units, including related cleaning activities, at the facility are below 2.7 tons per 12-month rolling period, before consideration of controls.

(3) Compliance with the VOC emission limits and other requirements of this section assures compliance with the VOC emission limits and other requirements of § 129.52 (relating to surface coating processes) for the miscellaneous metal parts and products surface coating processes as specified in § 129.52, Table I, Category 10.

**SECTION E. Source Group Restrictions.**

(4) If an owner or operator elects to comply with § 129.52e (relating to control of VOC emissions from automobile and light-duty truck assembly surface coating operations and heavier vehicle coating operations) under § 129.52e(a)(2) or (3), then § 129.52e instead of this section applies to the separate coating line at the facility, or to the coating of a body or body part for a new heavier vehicle at the facility, or both, for which the election is made.

(5) This section does not apply to an owner or operator in the use or application of the following:

(i) Aerosol coatings that meet the requirements of 40 CFR Part 59, Subpart E (relating to National volatile organic compound emission standards for aerosol coatings).

(ii) Aerospace coatings.

(iii) Architectural coatings.

(iv) Automobile refinishing coatings.

(v) Auto and light-duty truck assembly coatings.

(vi) Can, coil or magnet wire coatings.

(vii) Coating applied to a test panel or coupon, or both, in research and development, quality control or performance testing activities, if records are maintained as required under subsections (e) and (f).

(viii) Fiberglass boat manufacturing materials.

(ix) Flat wood paneling coatings.

(x) Large appliance coatings.

(xi) Metal furniture coatings.

(xii) Miscellaneous industrial adhesives.

(xiii) Paper, film and foil coatings.

(xiv) Shipbuilding and repair coatings.

(xv) Wood furniture coatings.

(b) Definitions. [INCORPORATED BY REFERENCE]

(c) Existing RACT permit. The requirements of this section supersede the requirements of a RACT permit issued under §§ 129.91—129.95 (relating to stationary sources of NO<sub>x</sub> and VOCs) to the owner or operator of a source subject to subsection (a) prior to January 1, 2017, to control, reduce or minimize VOCs from a miscellaneous metal part or miscellaneous plastic part surface coating process, except to the extent the RACT permit contains more stringent requirements.

(d) Emission limitations. Beginning January 1, 2017, a person subject to subsection (a)(1) may not cause or permit the emission into the outdoor atmosphere of VOCs from a miscellaneous metal part coating unit or miscellaneous plastic part coating unit, or both, unless emissions of VOCs are controlled in accordance with paragraph (1), (2) or (3).

(1) Compliant materials option. The VOC content of each miscellaneous metal part coating or each miscellaneous plastic part coating, as applied, excluding water and exempt compounds, is equal to or less than the VOC content limit for the applicable coating category specified in the applicable table of VOC content limits in Tables I—V.

**SECTION E. Source Group Restrictions.**

Table I. VOC Content Limits for Metal Parts and Products Surface Coatings Weight of VOC per Volume of Coating, Less Water and Exempt Compounds, as Applied.

Coating Category	Air Dried		Baked	
	kg VOC/ l coating	lb VOC/ gal coating	kg VOC/ l coating	lb VOC/ gal coating
General One-component	0.34	2.8	0.28	2.3
General Multicomponent	0.34	2.8	0.28	2.3
Camouflage	0.42	3.5	0.42	3.5
Extreme High-gloss	0.42	3.5	0.36	3.0
Extreme Performance	0.42	3.5	0.36	3.0
Heat-resistant	0.42	3.5	0.36	3.0
High-performance Architectural	0.74	6.2	0.74	6.2
High Temperature	0.42	3.5	0.42	3.5
Metallic	0.42	3.5	0.42	3.5
Military Specification	0.34	2.8	0.28	2.3
Prefabricated Architectural Multicomponent	0.42	3.5	0.28	2.3
Prefabricated Architectural One-Component	0.42	3.5	0.28	2.3
Touch-up and Repair	0.42	3.5	0.36	3.0

(2)-(3) [NA – NO VOC CONTROL DEVICE]

(4) Least restrictive VOC limit. If more than one VOC content limit or VOC emission rate limit applies to a specific coating, then the least restrictive VOC content limit or VOC emission rate limit applies.

(5) Coatings not listed in Table I, II, VI or VII. For a miscellaneous metal part or miscellaneous plastic part coating that does not meet the coating categories listed in Table I, II, VI or VII, the VOC content limit or VOC emission rate limit shall be determined by classifying the coating as a general one component coating or general multicomponent coating. The corresponding general one component coating or general multicomponent coating limit applies.

(6) Coatings not listed in Table IV or IX. [NA – FACILITY DOES NOT USE PLEASURE CRAFT COATINGS]

(e) Compliance and monitoring requirements.

(1) All owners and operators. Regardless of the facility's VOC emissions, the owner or operator of a miscellaneous metal part surface coating process or miscellaneous plastic part surface coating process, or both, subject to subsection (a)(1) or (2), shall comply with this section as specified throughout this section. For an owner or operator subject only to subsection (a)(2), the compliance requirements are the recordkeeping requirements in subsection (f)(2).

(2) [NA – NO VOC CONTROL DEVICE]

(f) Recordkeeping and reporting requirements.

(1) The owner or operator of a miscellaneous metal part coating unit or miscellaneous plastic part coating unit, or both, subject to subsection (a)(1) shall maintain monthly records sufficient to demonstrate compliance with this section. The records must include the following information:

(i) The following parameters for each coating, thinner, component and cleaning solvent as supplied:

(A) Name and identification number of the coating, thinner, other component or cleaning solvent.

(B) Volume used.

(C) Mix ratio.

**SECTION E. Source Group Restrictions.**

- (D) Density or specific gravity.
- (E) Weight percent of total volatiles, water, solids and exempt solvents.
- (F) Volume percent of total volatiles, water and exempt solvents for the applicable table of limits in Tables I—V.
- (G) Volume percent of solids for the applicable table of limits in Tables VI—IX.
- (ii) The VOC content of each coating, thinner, other component and cleaning solvent as supplied.
- (iii) The VOC content of each as applied coating or cleaning solvent.
- (iv) The calculations performed for each applicable requirement under subsections (d) and (e).
- (v) The information required in a plan approval issued under subsection (e)(2).
- (2) An owner or operator subject to subsection (a)(2), or otherwise claiming an exemption or exception in this section, shall maintain records sufficient to verify the applicability of subsection (a)(2), the exemption or exception. Records maintained for compliance demonstrations may include purchase, use, production and other records.
- (3) The records shall be maintained onsite for 2 years, unless a longer period is required by an order, plan approval or operating permit issued under Chapter 127 (relating to construction, modification, reactivation and operation of sources).
- (4) The records shall be submitted to the Department in an acceptable format upon receipt of a written request from the Department.
- (g) Coating application methods. A person subject to subsection (a)(1) may not cause or permit the emission into the outdoor atmosphere of VOCs from a miscellaneous metal part coating unit or miscellaneous plastic part coating unit, or both, unless the coatings are applied using one or more of the following coating application methods:
  - (1) Electrostatic coating.
  - (2) Flow coating.
  - (3) Dip coating, including electrodeposition.
  - (4) Roll coating.
  - (5) High volume-low pressure (HVLP) spray coating.
  - (6) Airless spray coating.
  - (7) Air-assisted airless spray coating.
  - (8) Other coating application method if approved in writing by the Department prior to use.
- (i) The coating application method must be capable of achieving a transfer efficiency equivalent to or better than that achieved by HVLP spray coating.
- (ii) The owner or operator shall submit the request for approval to the Department in writing.
- (h) Exempt coatings and exempt coating unit operations.
  - (1) The requirements of subsections (d) and (g) do not apply to the application of the following coatings to a metal part:
    - (i) Stencil coating.



**SECTION E. Source Group Restrictions.**

- (ii) Safety-indicating coating.
  - (iii) Solid-film lubricant.
  - (iv) Electric-insulating and thermal-conducting coating.
  - (v) Magnetic data storage disk coating.
  - (vi) Plastic extruded onto metal parts to form a coating.
  - (vii) Powder coating.
- (2) The requirements of subsection (d) do not apply to the application of the following coatings to a plastic part:
- (i) Touch-up and repair coating.
  - (ii) Stencil coating applied on a clear or transparent substrate.
  - (iii) Clear or translucent coating.
  - (iv) Coating applied at a paint manufacturing facility while conducting performance tests on coating.
  - (v) Reflective coating applied to highway cones.
  - (vi) Mask coating, if the coating is less than 0.5 millimeter thick (dried) and the area coated is less than 25 square inches.
  - (vii) EMI/RFI shielding coating.
  - (viii) Heparin-benzalkonium chloride (HBAC)-con-taining coating applied to a medical device, provided that the total usage of HBAC-containing coatings does not exceed 100 gallons in 1 calendar year at the facility.
  - (ix) Powder coating.
  - (x) An individual coating category used in an amount less than 50 gallons in 1 calendar year provided that the total usage of all of the coatings, combined, does not exceed 200 gallons per year at the facility. This exception applies only if substitute compliant coatings are not available.
- (3) The requirements of subsection (d) do not apply to the application of the following coatings to automotive-transportation and business machine parts:
- (i) Texture coat.
  - (ii) Vacuum-metalizing coating.
  - (iii) Gloss reducer.
  - (iv) Texture topcoat.
  - (v) Adhesion primer.
  - (vi) Electrostatic prep coat.
  - (vii) Resist coating.
  - (viii) Stencil coating.
  - (ix) Powder coating.

**SECTION E. Source Group Restrictions.**

(4) The requirements of subsection (g) do not apply to the following activities:

(i) Application of a touch-up coating, repair coating or textured finish to a metal part.

(ii) Application of a powder coating to the following:

(A) Plastic part.

(B) Automotive-transportation plastic part.

(C) Business machine plastic part.

(iii) Airbrush application of coating to a metal part or plastic part using no more than 5 gallons of coating per year.

(iv) Use of an add-on air pollution control device to comply with subsection (d).

(v) Application of extreme high-gloss coating in a pleasure craft surface coating operation.

(i) Work practice requirements for coating-related activities. The owner or operator of a miscellaneous metal part coating unit or miscellaneous plastic part coating unit, or both, subject to subsection (a)(1) shall comply with the following work practices for coating-related activities:

(1) Store all VOC-containing coatings, thinners or coating-related waste materials in closed containers.

(2) Ensure that mixing and storage containers used for VOC-containing coatings, thinners or coating-related waste materials are kept closed at all times, except when depositing or removing these coatings, thinners or waste materials.

(3) Minimize spills of VOC-containing coatings, thinners or coating-related waste materials and clean up spills immediately.

(4) Convey VOC-containing coatings, thinners or coating-related waste materials from one location to another in closed containers or pipes.

(j) Work practice requirements for cleaning materials. The owner or operator of a miscellaneous metal part coating unit or miscellaneous plastic part coating unit subject to subsection (a)(1) shall comply with the following work practices for cleaning materials:

(1) Store all VOC-containing cleaning materials and used shop towels in closed containers.

(2) Ensure that mixing vessels and storage containers used for VOC-containing cleaning materials are kept closed at all times except when depositing or removing these materials.

(3) Minimize spills of VOC-containing cleaning materials and clean up spills immediately.

(4) Convey VOC-containing cleaning materials from one location to another in closed containers or pipes.

(5) Minimize VOC emissions from cleaning of application, storage, mixing or conveying equipment by ensuring that equipment cleaning is performed without atomizing the cleaning solvent and all spent solvent is captured in closed containers.

(k) Measurements and calculations. To determine the properties of a coating or component used in a miscellaneous metal parts surface coating process or miscellaneous plastic parts surface coating process, measurements and calculations shall be performed according to one or more of the following:

(1) EPA Reference Method 24, Determination of Volatile Matter Content, Water Content, Density, Volume Solids, and Weight Solids of Surface Coatings, found at 40 CFR Part 60, Subpart D, Appendix A, including updates and revisions.

(2) Manufacturer's formulation data.

**SECTION E. Source Group Restrictions.**

- (3) Sampling and testing done in accordance with the procedures and test methods specified in Chapter 139.
- (4) Other test method demonstrated to provide results that are acceptable for purposes of determining compliance with this section if prior approval is obtained in writing from the Department.
- (5) [NA – NO VOC CONTROL DEVICE]
- (6) EPA calculations information in the following:
  - (i) A Guideline for Surface Coating Calculations, EPA-340/1-86-016, including updates and revisions.
  - (ii) Procedures for Certifying Quantity of Volatile Organic Compounds Emitted by Paint, Ink, and Other Coatings, EPA-450/3-84-019, including updates and revisions.

**SECTION E. Source Group Restrictions.**

Group Name: GROUP 3

Group Description: 40 CFR Part 60, Subpart Dc (NG Only)

**Sources included in this group**

ID	Name
034	CLAYTON BOILER (14.3 MMBTU/HR)

**I. RESTRICTIONS.**

No additional requirements exist except as provided in other sections of this permit including Section B (State Only General Requirements).

**II. TESTING REQUIREMENTS.**

No additional testing requirements exist except as provided in other sections of this permit including Section B (State Only General Requirements).

**III. MONITORING REQUIREMENTS.**

No additional monitoring requirements exist except as provided in other sections of this permit including Section B (State Only General Requirements).

**IV. RECORDKEEPING REQUIREMENTS.**

No additional record keeping requirements exist except as provided in other sections of this permit including Section B (State Only General Requirements).

**V. REPORTING REQUIREMENTS.**

No additional reporting requirements exist except as provided in other sections of this permit including Section B (State Only General Requirements).

**VI. WORK PRACTICE REQUIREMENTS.**

No additional work practice requirements exist except as provided in other sections of this permit including Section B (State Only General Requirements).

**VII. ADDITIONAL REQUIREMENTS.****# 001 [25 Pa. Code §127.441]****Operating permit terms and conditions.**

§ 60.40c Applicability and delegation of authority.

(a) Except as provided in paragraphs (d), (e), (f), and (g) of this section, the affected facility to which this subpart applies is each steam generating unit for which construction, modification, or reconstruction is commenced after June 9, 1989 and that has a maximum design heat input capacity of 29 megawatts (MW) (100 million British thermal units per hour (MMBtu/h)) or less, but greater than or equal to 2.9 MW (10 MMBtu/h).

(b) [NA - NOT SUBJECT TO PM OR SO2 STANDARDS]

(c) [NA - NOT SUBJECT TO PM OR SO2 STANDARDS]

(d) Any temporary change to an existing steam generating unit for the purpose of conducting combustion research is not considered a modification under § 60.14.

(e) [NA - SOURCES NOT ASSOCIATED WITH TURBINES]

(f) [NA - 4A AND 4C NOT APPLICABLE]

(g) [NA - 4B NOT APPLICABLE]

**SECTION E. Source Group Restrictions.**

(h) [NA - J AND Ja NOT APPLICABLE]

(i) [NA - UNIT(S) NOT TEMPORARY]

[72 FR 32759, June 13, 2007, as amended at 74 FR 5090, Jan. 28, 2009; 77 FR 9461, Feb. 16, 2012]

§ 60.42c Standard for sulfur dioxide (SO<sub>2</sub>).

(a) - (j) [NA - UNIT(S) DO NOT BURN COAL OR OIL]

[72 FR 32759, June 13, 2007, as amended at 74 FR 5090, Jan. 28, 2009; 77 FR 9462, Feb. 16, 2012]

§ 60.43c Standard for particulate matter (PM).

(a) - (e) [NA - UNIT(S) DO NOT BURN COAL, OIL OR WOOD]

[72 FR 32759, June 13, 2007, as amended at 74 FR 5091, Jan. 28, 2009; 77 FR 9462, Feb. 16, 2012]

§ 60.44c Compliance and performance test methods and procedures for sulfur dioxide.

[NA - NOT SUBJECT TO SO<sub>2</sub> STANDARD]

§ 60.45c Compliance and performance test methods and procedures for particulate matter.

[NA - NOT SUBJECT TO PM STANDARD]

§ 60.46c Emission monitoring for sulfur dioxide.

[NA - NOT SUBJECT TO SO<sub>2</sub> STANDARD]

§ 60.47c Emission monitoring for particulate matter.

[NA - NOT SUBJECT TO PM STANDARD]

§ 60.48c Reporting and recordkeeping requirements.

(a) [NA - REQUIREMENT IS IN THE PAST]

(b) - (f) [NA - NOT SUBJECT TO PM OR SO<sub>2</sub> STANDARDS]

(g)(1) Except as provided under paragraphs (g)(2) and (g)(3) of this section, the owner or operator of each affected facility shall record and maintain records of the amount of each fuel combusted during each operating day.

(2) As an alternative to meeting the requirements of paragraph (g)(1) of this section, the owner or operator of an affected facility that combusts only natural gas, wood, fuels using fuel certification in § 60.48c(f) to demonstrate compliance with the SO<sub>2</sub> standard, fuels not subject to an emissions standard (excluding opacity), or a mixture of these fuels may elect to record and maintain records of the amount of each fuel COMBUSTED during each calendar month.

(3) As an alternative to meeting the requirements of paragraph (g)(1) of this section, the owner or operator of an affected facility or multiple affected facilities located on a contiguous property unit where the only fuels combusted in any steam generating unit (including steam generating units not subject to this subpart) at that property are natural gas, wood, distillate oil meeting the most current requirements in § 60.42C to use fuel certification to demonstrate compliance with the SO<sub>2</sub> standard, and/or fuels, excluding coal and residual oil, not subject to an emissions standard (excluding opacity) may elect to record and maintain records of the total amount of each steam generating unit fuel DELIVERED to that property during each calendar month.

(h) [NA - NO CAPACITY FACTOR REQUIREMENT]

**SECTION E. Source Group Restrictions.**

(i) All records required under this section shall be maintained by the owner or operator of the affected facility for a period of two years following the date of such record.

(j) [NA – NO REPORTS REQUIRED]

[72 FR 32759, June 13, 2007, as amended at 74 FR 5091, Jan. 28, 2009]



**SECTION E. Source Group Restrictions.**

Group Name: GROUP 4

Group Description: 40 CFR Part 63, Subpart 6X

Sources included in this group

ID	Name
101	SURFACE COATING - TRACK 4
102	SURFACE COATING - TRACK 3
105	SHOT BLASTING
108	MACT SUBPART 6X ACTIVITIES
109	SURFACE COATING - TRACK 3

**I. RESTRICTIONS.**

No additional requirements exist except as provided in other sections of this permit including Section B (State Only General Requirements).

**II. TESTING REQUIREMENTS.**

No additional testing requirements exist except as provided in other sections of this permit including Section B (State Only General Requirements).

**III. MONITORING REQUIREMENTS.**

No additional monitoring requirements exist except as provided in other sections of this permit including Section B (State Only General Requirements).

**IV. RECORDKEEPING REQUIREMENTS.**

No additional record keeping requirements exist except as provided in other sections of this permit including Section B (State Only General Requirements).

**V. REPORTING REQUIREMENTS.**

No additional reporting requirements exist except as provided in other sections of this permit including Section B (State Only General Requirements).

**VI. WORK PRACTICE REQUIREMENTS.**

No additional work practice requirements exist except as provided in other sections of this permit including Section B (State Only General Requirements).

**VII. ADDITIONAL REQUIREMENTS.**

**# 001 [25 Pa. Code §127.441]  
Operating permit terms and conditions.**

§63.11514 Am I subject to this subpart?

(a) You are subject to this subpart if you own or operate an area source that is primarily engaged in the operations in one of the nine source categories listed in paragraphs (a)(1) through (9) of this section. Descriptions of these source categories are shown in Table 1 of this subpart. "Primarily engaged" is defined in §63.11522, "What definitions apply to this subpart?"

(1) [CATEGORY NOT APPLICABLE]

(2) Fabricated Metal Products

(3) Fabricated Plate Work (Boiler Shops)

(4)-(9) [CATEGORY NOT APPLICABLE]

(b) The provisions of this subpart apply to each new and existing affected source listed and defined in paragraphs (b)(1) through (5) of this section if you use materials that contain or have the potential to emit metal fabrication or finishing metal

**SECTION E. Source Group Restrictions.**

HAP (MFHAP), defined to be the compounds of cadmium, chromium, lead, manganese, and nickel, or any of these metals in the elemental form with the exception of lead. Materials that contain MFHAP are defined to be materials that contain greater than 0.1 percent for carcinogens, as defined by OSHA at 29 CFR 1910.1200(d)(4), and greater than 1.0 percent for noncarcinogens. For the MFHAP, this corresponds to materials that contain cadmium, chromium, lead, or nickel in amounts greater than or equal to 0.1 percent by weight (of the metal), and materials that contain manganese in amounts greater than or equal to 1.0 percent by weight (of the metal), as shown in formulation data provided by the manufacturer or supplier, such as the Material Safety Data Sheet for the material.

(1) A dry abrasive blasting affected source is the collection of all equipment and activities necessary to perform dry abrasive blasting operations which use materials that contain MFHAP or that have the potential to emit MFHAP.

(2) A machining affected source is the collection of all equipment and activities necessary to perform machining operations which use materials that contain MFHAP, as defined in §63.11522, "What definitions apply to this subpart?", or that have the potential to emit MFHAP.

(3) A dry grinding and dry polishing with machines affected source is the collection of all equipment and activities necessary to perform dry grinding and dry polishing with machines operations which use materials that contain MFHAP, as defined in §63.11522, "What definitions apply to this subpart?", or have the potential to emit MFHAP.

(4) A spray painting affected source is the collection of all equipment and activities necessary to perform spray-applied painting operations using paints which contain MFHAP. A spray painting affected source includes all equipment used to apply cleaning materials to a substrate to prepare it for paint application (surface preparation) or to remove dried paint; to apply a paint to a substrate (paint application) and to dry or cure the paint after application; or to clean paint operation equipment (equipment cleaning). Affected source(s) subject to the requirements of this paragraph are not subject to the miscellaneous surface coating provisions of subpart HHHHHH of this part, "National Emission Standards for Hazardous Air Pollutants: Paint Stripping and Miscellaneous Surface Coating Operations at Area Sources."

(5) A welding affected source is the collection of all equipment and activities necessary to perform welding operations which use materials that contain MFHAP, as defined in §63.11522, "What definitions apply to this subpart?", or have the potential to emit MFHAP.

(c) An affected source is existing if you commenced construction or reconstruction of the affected source, as defined in §63.2, "General Provisions" to part 63, before April 3, 2008.

(d) An affected source is new if you commenced construction or reconstruction of the affected source, as defined in §63.2, "General Provisions" to part 63, on or after April 3, 2008.

(e) [NA - NOT A RESEARCH OR LABORATORY FACILITY]

(f) This subpart does not apply to tool or equipment repair operations, facility maintenance, or quality control activities as defined in §63.11522, "What definitions apply to this subpart?"

(g) [NA - NOT AN ARMED FORCES, NASA, OR NNSA INSTALLATION]

(h) [NA - FACILITY DOES NOT PRODUCE MILITARY MUNITIONS OR EQUIPMENT USED FOR THE PURPOSE OF TRANSPORTING MILITARY MUNITIONS]

(i) You are exempt from the obligation to obtain a permit under 40 CFR part 70 or 40 CFR part 71, provided you are not otherwise required by law to obtain a permit under 40 CFR 70.3(a) or 40 CFR 71.3(a). Notwithstanding the previous sentence, you must continue to comply with the provisions of this subpart.

§63.11515 What are my compliance dates?

(a) If you own or operate an existing affected source, you must achieve compliance with the applicable provisions in this subpart by July 25, 2011.

(b) If you own or operate a new affected source, you must achieve compliance with the applicable provisions in this subpart



**SECTION E. Source Group Restrictions.**

by July 23, 2008, or upon startup of your affected source, whichever is later.

**STANDARDS AND COMPLIANCE REQUIREMENTS**

§63.11516 What are my standards and management practices?

(a) Dry abrasive blasting standards. If you own or operate a new or existing dry abrasive blasting affected source, you must comply with the requirements in paragraphs (a)(1) through (3) of this section, as applicable, for each dry abrasive blasting operation that uses materials that contain MFHAP, as defined in §63.11522, "What definitions apply to this subpart?", or has the potential to emit MFHAP. These requirements do not apply when abrasive blasting operations are being performed that do not use any materials containing MFHAP or do not have the potential to emit MFHAP.

(1) [NA – FACILITY DOES NOT INCLUDE DRY ABRASIVE BLASTING OF OBJECTS PERFORMED IN TOTALLY ENCLOSED AND UNVENTED BLAST CHAMBERS]

(2) Standards for dry abrasive blasting of objects performed in vented enclosures. If you own or operate a new or existing dry abrasive blasting affected source which consists of a dry abrasive blasting operation which has a vent allowing any air or blast material to escape, you must comply with the requirements in paragraphs (a)(2)(i) and (ii) of this section. Dry abrasive blasting operations for which the items to be blasted exceed 8 feet (2.4 meters) in any dimension, may be performed subject to the requirements in paragraph (a)(3) of this section.

(i) You must capture emissions and vent them to a filtration control device. You must operate the filtration control device according to manufacturer's instructions, and you must demonstrate compliance with this requirement by maintaining a record of the manufacturer's specifications for the filtration control devices, as specified by the requirements in §63.11519(c)(4), "What are my notification, recordkeeping, and reporting requirements?"

(ii) You must implement the management practices to minimize emissions of MFHAP as specified in paragraphs (a)(2)(ii)(A) through (C) of this section.

(A) You must take measures necessary to minimize excess dust in the surrounding area to reduce MFHAP emissions, as practicable; and

(B) You must enclose dusty abrasive material storage areas and holding bins, seal chutes and conveyors that transport abrasive materials; and

(C) You must operate all equipment associated with dry abrasive blasting operations according to manufacturer's instructions.

(3) Standards for dry abrasive blasting of objects greater than 8 feet (2.4 meters) in any one dimension. If you own or operate a new or existing dry abrasive blasting affected source which consists of a dry abrasive blasting operation which is performed on objects greater than 8 feet (2.4 meters) in any one dimension, you may implement management practices to minimize emissions of MFHAP as specified in paragraph (a)(3)(i) of this section instead of the practices required by paragraph (a)(2) of this section. You must demonstrate that management practices are being implemented by complying with the requirements in paragraphs (a)(3)(ii) through (iv) of this section.

(i) Management practices for dry abrasive blasting of objects greater than 8 feet (2.4 meters) in any one dimension are specified in paragraphs (a)(3)(i)(A) through (E) of this section.

(A) You must take measures necessary to minimize excess dust in the surrounding area to reduce MFHAP emissions, as practicable; and

(B) You must enclose abrasive material storage areas and holding bins, seal chutes and conveyors that transport abrasive material; and

(C) You must operate all equipment associated with dry abrasive blasting operations according to manufacturer's instructions; and

**SECTION E. Source Group Restrictions.**

- (D) You must not re-use dry abrasive blasting media unless contaminants (i.e., any material other than the base metal, such as paint residue) have been removed by filtration or screening, and the abrasive material conforms to its original size; and
- (E) Whenever practicable, you must switch from high particulate matter (PM)-emitting blast media (e.g., sand) to low PM-emitting blast media (e.g., crushed glass, specular hematite, steel shot, aluminum oxide), where PM is a surrogate for MFHAP.
- (ii) You must perform visual determinations of fugitive emissions, as specified in § 63.11517(b), "What are my monitoring requirements?", according to paragraphs (a)(3)(ii)(A) or (B) of this section, as applicable.
- (A) For abrasive blasting of objects greater than 8 feet (2.4 meters) in any one dimension that is performed outdoors, you must perform visual determinations of fugitive emissions at the fenceline or property border nearest to the outdoor dry abrasive blasting operation.
- (B) For abrasive blasting of objects greater than 8 feet (2.4 meters) in any one dimension that is performed indoors, you must perform visual determinations of fugitive emissions at the primary vent, stack, exit, or opening from the building containing the abrasive blasting operations.
- (iii) You must keep a record of all visual determinations of fugitive emissions along with any corrective action taken in accordance with the requirements in § 63.11519(c)(2), "What are my notification, recordkeeping, and reporting requirements?"
- (iv) If visible fugitive emissions are detected, you must perform corrective actions until the visible fugitive emissions are eliminated, at which time you must comply with the requirements in paragraphs (a)(3)(iv)(A) and (B) of this section.
- (A) You must perform a follow-up inspection for visible fugitive emissions in accordance with § 63.11517(a), "Monitoring Requirements."
- (B) You must report all instances where visible emissions are detected, along with any corrective action taken and the results of subsequent follow-up inspections for visible emissions, with your annual certification and compliance report as required by § 63.11519(b)(5), "Notification, recordkeeping, and reporting requirements."
- (b) Standards for machining. If you own or operate a new or existing machining affected source, you must implement management practices to minimize emissions of MFHAP as specified in paragraph (b)(1) and (2) of this section for each machining operation that uses materials that contain MFHAP, as defined in §63.11522, "What definitions apply to this subpart?", or has the potential to emit MFHAP. These requirements do not apply when machining operations are being performed that do not use any materials containing MFHAP and do not have the potential to emit MFHAP.
- (1) You must take measures necessary to minimize excess dust in the surrounding area to reduce MFHAP emissions, as practicable; and
- (2) You must operate all equipment associated with machining according to manufacturer's instructions.
- (c) [NA - FACILITY DOES NOT CONDUCT DRY GRINDING OR DRY POLISHING WITH STATIONARY MACHINES]
- (d) Standards for control of MFHAP in spray painting. If you own or operate a new or existing spray painting affected source, as defined in §63.11514 (b)(4), "Am I subject to this subpart?," you must implement the management practices in paragraphs (d)(1) through (9) of this section when a spray-applied paint that contains MFHAP is being applied. These requirements do not apply when spray-applied paints that do not contain MFHAP are being applied.
- (1) Standards for spray painting for MFHAP control. All spray-applied painting of objects must meet the requirements of paragraphs (d)(1)(i) through (iii) of this section. These requirements do not apply to affected sources located at Fabricated Structural Metal Manufacturing facilities, as described in Table 1, "Description of Source Categories Affected by this Subpart," or affected sources that spray paint objects greater than 15 feet (4.57 meters), that are not spray painted in spray booths or spray rooms.

**SECTION E. Source Group Restrictions.**

- (i) Spray booths or spray rooms must have a full roof, at least two complete walls, and one or two complete side curtains or other barrier material so that all four sides are covered. The spray booths or spray rooms must be ventilated so that air is drawn into the booth and leaves only through the filter. The roof may contain narrow slots for connecting fabricated products to overhead cranes, and/or for cords or cables.
- (ii) All spray booths or spray rooms must be fitted with a type of filter technology that is demonstrated to achieve at least 98 percent capture of MFHAP. The procedure used to demonstrate filter efficiency must be consistent with the American Society of Heating, Refrigerating, and Air-Conditioning Engineers (ASHRAE) Method 52.1, "Gravimetric and Dust-Spot Procedures for Testing Air-Cleaning Devices Used in General Ventilation for Removing Particulate Matter, June 4, 1992" (incorporated by reference, see §63.14). The test coating for measuring filter efficiency shall be a high-solids bake enamel delivered at a rate of at least 135 grams per minute from a conventional (non-High Volume Low Pressure) air-atomized spray gun operating at 40 psi air pressure; the air flow rate across the filter shall be 150 feet per minute. Owners and operators may use published filter efficiency data provided by filter vendors to demonstrate compliance with this requirement and are not required to perform this measurement.
- (iii) You must perform regular inspection and replacement of the filters in all spray booths or spray rooms according to manufacturer's instructions, and maintain documentation of these activities, as detailed in §63.11519(c)(5), "Notification, recordkeeping, and reporting requirements."
- (iv) As an alternative compliance requirement, spray booths or spray rooms equipped with a water curtain, called "waterwash" or "waterspray" booths or spray rooms that are operated and maintained according to the manufacturer's specifications and that achieve at least 98 percent control of MFHAP, may be used in lieu of the spray booths or spray rooms requirements of paragraphs (d)(1)(i) through (iii) of this section.
- (2) Standards for spray painting application equipment of all objects painted for MFHAP control. All paints applied via spray-applied painting must be applied with a high-volume, low-pressure (HVLP) spray gun, electrostatic application, airless spray gun, air-assisted airless spray gun, or an equivalent technology that is demonstrated to achieve transfer efficiency comparable to one of these spray gun technologies for a comparable operation, and for which written approval has been obtained from the Administrator. The procedure used to demonstrate that spray gun transfer efficiency is equivalent to that of an HVLP spray gun must be equivalent to the California South Coast Air Quality Management District's "Spray Equipment Transfer Efficiency Test Procedure for Equipment User, May 24, 1989" and "Guidelines for Demonstrating Equivalency with District Approved Transfer Efficient Spray Guns, September 26, 2002", Revision 0 (incorporated by reference, see §63.14).
- (3) Spray system recordkeeping. You must maintain documentation of the HVLP or other high transfer efficiency spray paint delivery methods, as detailed in §63.11519(c)(7), "Notification, recordkeeping, and reporting requirements."
- (4) Spray gun cleaning. All cleaning of paint spray guns must be done with either non-HAP gun cleaning solvents, or in such a manner that an atomized mist of spray of gun cleaning solvent and paint residue is not created outside of a container that collects the used gun cleaning solvent. Spray gun cleaning may be done with, for example, by hand cleaning of parts of the disassembled gun in a container of solvent, by flushing solvent through the gun without atomizing the solvent and paint residue, or by using a fully enclosed spray gun washer. A combination of these non-atomizing methods may also be used.
- (5) Spray painting worker certification. All workers performing painting must be certified that they have completed training in the proper spray application of paints and the proper setup and maintenance of spray equipment. The minimum requirements for training and certification are described in paragraph (d)(6) of this section. The spray application of paint is prohibited by persons who are not certified as having completed the training described in paragraph (d)(6) of this section. The requirements of this paragraph do not apply to the students of an accredited painting training program who are under the direct supervision of an instructor who meets the requirements of this paragraph. The requirements of this paragraph do not apply to operators of robotic or automated painting operations.
- (6) Spray painting training program content. Each owner or operator of an affected spray painting affected source must ensure and certify that all new and existing personnel, including contract personnel, who spray apply paints are trained in the proper application of paints as required by paragraph (d)(5) of this section. The training program must include, at a minimum, the items listed in paragraphs (d)(6)(i) through (iii) of this section.
- (i) A list of all current personnel by name and job description who are required to be trained;

**SECTION E. Source Group Restrictions.**

(ii) Hands-on, or in-house or external classroom instruction that addresses, at a minimum, initial and refresher training in the topics listed in paragraphs (d)(6)(ii)(A) through (D) of this section.

(A) Spray gun equipment selection, set up, and operation, including measuring paint viscosity, selecting the proper fluid tip or nozzle, and achieving the proper spray pattern, air pressure and volume, and fluid delivery rate.

(B) Spray technique for different types of paints to improve transfer efficiency and minimize paint usage and overspray, including maintaining the correct spray gun distance and angle to the part, using proper banding and overlap, and reducing lead and lag spraying at the beginning and end of each stroke.

(C) Routine spray booth and filter maintenance, including filter selection and installation.

(D) Environmental compliance with the requirements of this subpart.

(iii) A description of the methods to be used at the completion of initial or refresher training to demonstrate, document, and provide certification of successful completion of the required training. Alternatively, owners and operators who can show by documentation or certification that a painter's work experience and/or training has resulted in training equivalent to the training required in paragraph (d)(6)(ii) of this section are not required to provide the initial training required by that paragraph to these painters.

(7) Records of spray painting training. You must maintain records of employee training certification for use of HVLP or other high transfer efficiency spray paint delivery methods as detailed in §63.11519(c)(8), "Notification, recordkeeping, and reporting requirements."

(8) Spray painting training dates. As required by paragraph (d)(5) of this section, all new and existing personnel at an affected spray painting affected source, including contract personnel, who spray apply paints must be trained by the dates specified in paragraphs (d)(8)(i) and (ii) of this section.

(i) If your source is a new source, all personnel must be trained and certified no later than January 20, 2009, 180 days after startup, or 180 days after hiring, whichever is later. Training that was completed within 5 years prior to the date training is required, and that meets the requirements specified in paragraph (d)(6)(ii) of this section satisfies this requirement and is valid for a period not to exceed 5 years after the date the training is completed.

(ii) If your source is an existing source, all personnel must be trained and certified no later than July 25, 2011, or 180 days after hiring, whichever is later. Worker training that was completed within 5 years prior to the date training is required, and that meets the requirements specified in paragraph (d)(6)(ii) of this section, satisfies this requirement and is valid for a period not to exceed 5 years after the date the training is completed.

(9) Duration of training validity. Training and certification will be valid for a period not to exceed 5 years after the date the training is completed. All personnel must receive refresher training that meets the requirements of this section and be re-certified every 5 years.

(e) [Reserved]

(f) Standards for welding. If you own or operate a new or existing welding affected source, you must comply with the requirements in paragraphs (f)(1) and (2) of this section for each welding operation that uses materials that contain MFHAP, as defined in §63.11522, "What definitions apply to this subpart?", or has the potential to emit MFHAP. If your welding affected source uses 2,000 pounds or more per year of welding rod containing one or more MFHAP (calculated on a rolling 12-month basis), you must demonstrate that management practices or fume control measures are being implemented by complying with the requirements in paragraphs (f)(3) through (8) of this section. The requirements in paragraphs (f)(1) through (8) of this section do not apply when welding operations are being performed that do not use any materials containing MFHAP or do not have the potential to emit MFHAP.

(1) You must operate all equipment, capture, and control devices associated with welding operations according to manufacturer's instructions. You must demonstrate compliance with this requirement by maintaining a record of the manufacturer's specifications for the capture and control devices, as specified by the requirements in §63.11519(c)(4), "Notification, recordkeeping, and reporting requirements."

**SECTION E. Source Group Restrictions.**

(2) You must implement one or more of the management practices specified in paragraphs (f)(2)(i) through (v) of this section to minimize emissions of MFHAP, as practicable, while maintaining the required welding quality through the application of sound engineering judgment.

(i) Use welding processes with reduced fume generation capabilities (e.g., gas metal arc welding (GMAW)—also called metal inert gas welding (MIG));

(ii) Use welding process variations (e.g., pulsed current GMAW), which can reduce fume generation rates;

(iii) Use welding filler metals, shielding gases, carrier gases, or other process materials which are capable of reduced welding fume generation;

(iv) Optimize welding process variables (e.g., electrode diameter, voltage, amperage, welding angle, shield gas flow rate, travel speed) to reduce the amount of welding fume generated; and

(v) Use a welding fume capture and control system, operated according to the manufacturer's specifications.

(3) Tier 1 compliance requirements for welding. You must perform visual determinations of welding fugitive emissions as specified in §63.11517(b), "Monitoring requirements," at the primary vent, stack, exit, or opening from the building containing the welding operations. You must keep a record of all visual determinations of fugitive emissions along with any corrective action taken in accordance with the requirements in §63.11519(c)(2), "Notification, recordkeeping, and reporting requirements."

(4) Requirements upon initial detection of visible emissions from welding. If visible fugitive emissions are detected during any visual determination required in paragraph (f)(3) of this section, you must comply with the requirements in paragraphs (f)(4)(i) and (ii) of this section.

(i) Perform corrective actions that include, but are not limited to, inspection of welding fume sources, and evaluation of the proper operation and effectiveness of the management practices or fume control measures implemented in accordance with paragraph (f)(2) of this section. After completing such corrective actions, you must perform a follow-up inspection for visible fugitive emissions in accordance with §63.11517(a), "Monitoring Requirements," at the primary vent, stack, exit, or opening from the building containing the welding operations.

(ii) Report all instances where visible emissions are detected, along with any corrective action taken and the results of subsequent follow-up inspections for visible emissions, and submit with your annual certification and compliance report as required by §63.11519(b)(5), "Notification, recordkeeping, and reporting requirements."

(5) Tier 2 requirements upon subsequent detection of visible emissions. If visible fugitive emissions are detected more than once during any consecutive 12 month period (notwithstanding the results of any follow-up inspections), you must comply with paragraphs (f)(5)(i) through (iv) of this section.

(i) Within 24 hours of the end of the visual determination of fugitive emissions in which visible fugitive emissions were detected, you must conduct a visual determination of emissions opacity, as specified in §63.11517(c), "Monitoring requirements," at the primary vent, stack, exit, or opening from the building containing the welding operations.

(ii) In lieu of the requirement of paragraph (f)(3) of this section to perform visual determinations of fugitive emissions with EPA Method 22, you must perform visual determinations of emissions opacity in accordance with §63.11517(d), "Monitoring Requirements," using EPA Method 9, at the primary vent, stack, exit, or opening from the building containing the welding operations.

(iii) You must keep a record of each visual determination of emissions opacity performed in accordance with paragraphs (f)(5)(i) or (ii) of this section, along with any subsequent corrective action taken, in accordance with the requirements in §63.11519(c)(3), "Notification, recordkeeping, and reporting requirements."

(iv) You must report the results of all visual determinations of emissions opacity performed in accordance with paragraphs (f)(5)(i) or (ii) of this section, along with any subsequent corrective action taken, and submit with your annual certification and compliance report as required by §63.11519(b)(6), "Notification, recordkeeping, and reporting requirements."

**SECTION E. Source Group Restrictions.**

(6) Requirements for opacities less than or equal to 20 percent but greater than zero. For each visual determination of emissions opacity performed in accordance with paragraph (f)(5) of this section for which the average of the six-minute average opacities recorded is 20 percent or less but greater than zero, you must perform corrective actions, including inspection of all welding fume sources, and evaluation of the proper operation and effectiveness of the management practices or fume control measures implemented in accordance with paragraph (f)(2) of this section.

(7) Tier 3 requirements for opacities exceeding 20 percent. For each visual determination of emissions opacity performed in accordance with paragraph (f)(5) of this section for which the average of the six-minute average opacities recorded exceeds 20 percent, you must comply with the requirements in paragraphs (f)(7)(i) through (v) of this section.

(i) You must submit a report of exceedence of 20 percent opacity, along with your annual certification and compliance report, as specified in §63.11519(b)(8), "Notification, recordkeeping, and reporting requirements," and according to the requirements of §63.11519(b)(1), "Notification, recordkeeping, and reporting requirements."

(ii) Within 30 days of the opacity exceedence, you must prepare and implement a Site-Specific Welding Emissions Management Plan, as specified in paragraph (f)(8) of this section. If you have already prepared a Site-Specific Welding Emissions Management Plan in accordance with this paragraph, you must prepare and implement a revised Site-Specific Welding Emissions Management Plan within 30 days.

(iii) During the preparation (or revision) of the Site-Specific Welding Emissions Management Plan, you must continue to perform visual determinations of emissions opacity, beginning on a daily schedule as specified in §63.11517(d), "Monitoring Requirements," using EPA Method 9, at the primary vent, stack, exit, or opening from the building containing the welding operations.

(iv) You must maintain records of daily visual determinations of emissions opacity performed in accordance with paragraph (f)(7)(iii) of this section, during preparation of the Site-Specific Welding Emissions Management Plan, in accordance with the requirements in §63.11519(b)(9), "Notification, recordkeeping, and reporting requirements."

(v) You must include these records in your annual certification and compliance report, according to the requirements of §63.11519(b)(1), "Notification, recordkeeping, and reporting requirements."

(8) Site-Specific Welding Emissions Management Plan. The Site-Specific Welding Emissions Management Plan must comply with the requirements in paragraphs (f)(8)(i) through (iii) of this section.

(i) Site-Specific Welding Emissions Management Plan must contain the information in paragraphs (f)(8)(i)(A) through (F) of this section.

(A) Company name and address;

(B) A list and description of all welding operations which currently comprise the welding affected source;

(C) A description of all management practices and/or fume control methods in place at the time of the opacity exceedence;

(D) A list and description of all management practices and/or fume control methods currently employed for the welding affected source;

(E) A description of additional management practices and/or fume control methods to be implemented pursuant to paragraph (f)(7)(ii) of this section, and the projected date of implementation; and

(F) Any revisions to a Site-Specific Welding Emissions Management Plan must contain copies of all previous plan entries, pursuant to paragraphs (f)(8)(i)(D) and (E) of this section.

(ii) The Site-Specific Welding Emissions Management Plan must be updated annually to contain current information, as required by paragraphs (f)(8)(i)(A) through (C) of this section, and submitted with your annual certification and compliance report, according to the requirements of §63.11519(b)(1), "Notification, recordkeeping, and reporting requirements."

(iii) You must maintain a copy of the current Site-Specific Welding Emissions Management Plan in your records in a readily-



**SECTION E. Source Group Restrictions.**

accessible location for inspector review, in accordance with the requirements in §63.11519(c)(12), "Notification, recordkeeping, and reporting requirements."

§63.11517 What are my monitoring requirements?

(a) Visual determination of fugitive emissions, general. Visual determination of fugitive emissions must be performed according to the procedures of EPA Method 22, of 40 CFR part 60, Appendix A-7. You must conduct the EPA Method 22 test while the affected source is operating under normal conditions. The duration of each EPA Method 22 test must be at least 15 minutes, and visible emissions will be considered to be present if they are detected for more than six minutes of the fifteen minute period.

(b) Visual determination of fugitive emissions, graduated schedule. Visual determinations of fugitive emissions must be performed in accordance with paragraph (a) of this section and according to the schedule in paragraphs (b)(1) through (4) of this section.

(1) Daily Method 22 Testing. Perform visual determination of fugitive emissions once per day, on each day the process is in operation, during operation of the process.

(2) Weekly Method 22 Testing. If no visible fugitive emissions are detected in consecutive daily EPA Method 22 tests, performed in accordance with paragraph (b)(1) of this section for 10 days of work day operation of the process, you may decrease the frequency of EPA Method 22 testing to once every five days of operation of the process (one calendar week). If visible fugitive emissions are detected during these tests, you must resume EPA Method 22 testing of that operation once per day during each day that the process is in operation, in accordance with paragraph (b)(1) of this section.

(3) Monthly Method 22 Testing. If no visible fugitive emissions are detected in four consecutive weekly EPA Method 22 tests performed in accordance with paragraph (b)(2) of this section, you may decrease the frequency of EPA Method 22 testing to once per 21 days of operation of the process (one calendar month). If visible fugitive emissions are detected during these tests, you must resume weekly EPA Method 22 in accordance with paragraph (b)(2) of this section.

(4) Quarterly Method 22 Testing. If no visible fugitive emissions are detected in three consecutive monthly EPA Method 22 tests performed in accordance with paragraph (b)(3) of this section, you may decrease the frequency of EPA Method 22 testing to once per 60 days of operation of the process (3 calendar months). If visible fugitive emissions are detected during these tests, you must resume monthly EPA Method 22 in accordance with paragraph (b)(3) of this section.

(c) Visual determination of emissions opacity for welding Tier 2 or 3, general. Visual determination of emissions opacity must be performed in accordance with the procedures of EPA Method 9, of 40 CFR part 60, Appendix A-4, and while the affected source is operating under normal conditions. The duration of the EPA Method 9 test shall be thirty minutes.

(d) Visual determination of emissions opacity for welding Tier 2 or 3, graduated schedule. You must perform visual determination of emissions opacity in accordance with paragraph (c) of this section and according to the schedule in paragraphs (d)(1) through (5) of this section.

(1) Daily Method 9 testing for welding, Tier 2 or 3. Perform visual determination of emissions opacity once per day during each day that the process is in operation.

(2) Weekly Method 9 testing for welding, Tier 2 or 3. If the average of the six minute opacities recorded during any of the daily consecutive EPA Method 9 tests performed in accordance with paragraph (d)(1) of this section does not exceed 20 percent for 10 days of operation of the process, you may decrease the frequency of EPA Method 9 testing to once per five days of consecutive work day operation. If opacity greater than 20 percent is detected during any of these tests, you must resume testing every day of operation of the process according to the requirements of paragraph (d)(1) of this section.

(3) Monthly Method 9 testing for welding Tier 2 or 3. If the average of the six minute opacities recorded during any of the consecutive weekly EPA Method 9 tests performed in accordance with paragraph (d)(2) of this section does not exceed 20 percent for four consecutive weekly tests, you may decrease the frequency of EPA Method 9 testing to once per every 21 days of operation of the process. If visible emissions opacity greater than 20 percent is detected during any monthly test, you must resume testing every five days of operation of the process according to the requirements of paragraph (d)(2) of this section.

**SECTION E. Source Group Restrictions.**

(4) Quarterly Method 9 testing for welding Tier 2 or 3. If the average of the six minute opacities recorded during any of the consecutive weekly EPA Method 9 tests performed in accordance with paragraph (d)(3) of this section does not exceed 20 percent for three consecutive monthly tests, you may decrease the frequency of EPA Method 9 testing to once per every 120 days of operation of the process. If visible emissions opacity greater than 20 percent is detected during any quarterly test, you must resume testing every 21 days (month) of operation of the process according to the requirements of paragraph (d)(3) of this section.

(5) Return to Method 22 testing for welding, Tier 2 or 3. If, after two consecutive months of testing, the average of the six minute opacities recorded during any of the monthly EPA Method 9 tests performed in accordance with paragraph (d)(3) of this section does not exceed 20 percent, you may resume EPA Method 22 testing as in paragraphs (b)(3) and (4) of this section. In lieu of this, you may elect to continue performing EPA Method 9 tests in accordance with paragraphs (d)(3) and (4) of this section.

§63.11518 [Reserved]

§63.11519 What are my notification, recordkeeping, and reporting requirements?

(a) What notifications must I submit?—(1) [A SIGNED INITIAL NOTIFICATION WAS RECEIVED ON MARCH 23, 2021]

(2) Notification of compliance status. If you are the owner or operator of an existing affected source, you must submit a notification of compliance status on or before November 22, 2011. If you are the owner or operator of a new affected source, you must submit a notification of compliance status within 120 days after initial startup, or by November 20, 2008, whichever is later. You are required to submit the information specified in paragraphs (a)(2)(i) through (iv) of this section with your notification of compliance status:

(i) Your company's name and address;

(ii) A statement by a responsible official with that official's name, title, phone number, e-mail address and signature, certifying the truth, accuracy, and completeness of the notification and a statement of whether the source has complied with all the relevant standards and other requirements of this subpart;

(iii) If you operate any spray painting affected sources, the information required by §63.11516(e)(3)(vi)(C), "Compliance demonstration," or § 63.11516(e)(4)(ix)(C), "Compliance demonstration," as applicable; and

(iv) The date of the notification of compliance status.

(b) What reports must I prepare or submit?—(1) Annual certification and compliance reports. You must prepare and submit annual certification and compliance reports for each affected source according to the requirements of paragraphs (b)(2) through (7) of this section. The annual certification and compliance reporting requirements may be satisfied by reports required under other parts of the CAA, as specified in paragraph (b)(3) of this section.

(2) Dates. Unless the Administrator has approved or agreed to a different schedule for submission of reports under §63.10(a), "General Provisions," you must prepare and submit each annual certification and compliance report according to the dates specified in paragraphs (b)(2)(i) through (iii) of this section. Note that the information reported for each of the months in the reporting period will be based on the last 12 months of data prior to the date of each monthly calculation.

(i) The first annual certification and compliance report must cover the first annual reporting period which begins the day after the compliance date and ends on December 31.

(ii) Each subsequent annual certification and compliance report must cover the subsequent semiannual reporting period from January 1 through December 31.

(iii) Each annual certification and compliance report must be prepared and submitted no later than January 31 and kept in a readily-accessible location for inspector review. If an exceedance has occurred during the year, each annual certification and compliance report must be submitted along with the exceedance reports, and postmarked or delivered no later than January 31.



**SECTION E. Source Group Restrictions.****(3) [ALTERNATE REPORT DATES NOT REQUESTED]**

(4) General requirements. The annual certification and compliance report must contain the information specified in paragraphs (b)(4)(i) through (iii) of this section, and the information specified in paragraphs (b)(5) through (7) of this section that is applicable to each affected source.

(i) Company name and address;

(ii) Statement by a responsible official with that official's name, title, and signature, certifying the truth, accuracy, and completeness of the content of the report; and

(iii) Date of report and beginning and ending dates of the reporting period. The reporting period is the 12-month period ending on December 31. Note that the information reported for the 12 months in the reporting period will be based on the last 12 months of data prior to the date of each monthly calculation.

(5) Visual determination of fugitive emissions requirements. The annual certification and compliance report must contain the information specified in paragraphs (b)(5)(i) through (iii) of this section for each affected source which performs visual determination of fugitive emissions in accordance with §63.11517(a), "Monitoring requirements."

(i) The date of every visual determination of fugitive emissions which resulted in detection of visible emissions;

(ii) A description of the corrective actions taken subsequent to the test; and

(iii) The date and results of the follow-up visual determination of fugitive emissions performed after the corrective actions.

(6) Visual determination of emissions opacity requirements. The annual certification and compliance report must contain the information specified in paragraphs (b)(6)(i) through (iii) of this section for each affected source which performs visual determination of emissions opacity in accordance with §63.11517(c), "Monitoring requirements."

(i) The date of every visual determination of emissions opacity;

(ii) The average of the six-minute opacities measured by the test; and

(iii) A description of any corrective action taken subsequent to the test.

**(7) [Reserved]**

(8) Exceedences of 20 percent opacity for welding affected sources. As required by §63.11516(f)(7)(i), "Requirements for opacities exceeding 20 percent," you must prepare an exceedence report whenever the average of the six-minute average opacities recorded during a visual determination of emissions opacity exceeds 20 percent. This report must be submitted along with your annual certification and compliance report according to the requirements in paragraph (b)(1) of this section, and must contain the information in paragraphs (b)(8)(iii)(A) and (B) of this section.

(A) The date on which the exceedence occurred; and

(B) The average of the six-minute average opacities recorded during the visual determination of emissions opacity.

(9) Site-specific Welding Emissions Management Plan reporting. You must submit a copy of the records of daily visual determinations of emissions recorded in accordance with §63.11516(f)(7)(iv), "Tier 3 requirements for opacities exceeding 20 percent," and a copy of your Site-Specific Welding Emissions Management Plan and any subsequent revisions to the plan pursuant to §63.11516(f)(8), "Site-specific Welding Emission Management Plan," along with your annual certification and compliance report, according to the requirements in paragraph (b)(1) of this section.

(c) What records must I keep? You must collect and keep records of the data and information specified in paragraphs (c)(1) through (13) of this section, according to the requirements in paragraph (c)(14) of this section.

(1) General compliance and applicability records. Maintain information specified in paragraphs (c)(1)(i) through (ii) of this

**SECTION E. Source Group Restrictions.**

section for each affected source.

- (i) Each notification and report that you submitted to comply with this subpart, and the documentation supporting each notification and report.
  - (ii) Records of the applicability determinations as in §63.11514(b)(1) through (5), "Am I subject to this subpart," listing equipment included in its affected source, as well as any changes to that and on what date they occurred, must be maintained for 5 years and be made available for inspector review at any time.
- (2) Visual determination of fugitive emissions records. Maintain a record of the information specified in paragraphs (c)(2)(i) through (iii) of this section for each affected source which performs visual determination of fugitive emissions in accordance with §63.11517(a), "Monitoring requirements."
- (i) The date and results of every visual determination of fugitive emissions;
  - (ii) A description of any corrective action taken subsequent to the test; and
  - (iii) The date and results of any follow-up visual determination of fugitive emissions performed after the corrective actions.
- (3) Visual determination of emissions opacity records. Maintain a record of the information specified in paragraphs (c)(3)(i) through (iii) of this section for each affected source which performs visual determination of emissions opacity in accordance with §63.11517(c), "Monitoring requirements."
- (i) The date of every visual determination of emissions opacity; and
  - (ii) The average of the six-minute opacities measured by the test; and
  - (iii) A description of any corrective action taken subsequent to the test.
- (4) Maintain a record of the manufacturer's specifications for the control devices used to comply with §63.11516, "What are my standards and management practices?"
- (5) Spray paint booth filter records. Maintain a record of the filter efficiency demonstrations and spray paint booth filter maintenance activities, performed in accordance with §63.11516(d)(1)(ii) and (iii), "Requirements for spray painting objects in spray booths or spray rooms."
- (6) Waterspray booth or water curtain efficiency tests. Maintain a record of the water curtain efficiency demonstrations performed in accordance with §63.11516(d)(1)(ii), "Requirements for spray painting objects in spray booths or spray rooms."
- (7) HVLP or other high transfer efficiency spray delivery system documentation records. Maintain documentation of HVLP or other high transfer efficiency spray paint delivery systems, in compliance with §63.11516(d)(3), "Requirements for spray painting of all objects." This documentation must include the manufacturer's specifications for the equipment and any manufacturer's operation instructions. If you have obtained written approval for an alternative spray application system in accordance with §63.11516(d)(2), "Spray painting of all objects," you must maintain a record of that approval along with documentation of the demonstration of equivalency.
- (8) HVLP or other high transfer efficiency spray delivery system employee training documentation records. Maintain certification that each worker performing spray painting operations has completed the training specified in §63.11516(d)(6), "Requirements for spray painting of all objects," with the date the initial training and the most recent refresher training was completed.
- (9)-(10) [Reserved]
- (11) Visual determination of emissions opacity performed during the preparation (or revision) of the Site-Specific Welding Emissions Management Plan. You must maintain a record of each visual determination of emissions opacity performed during the preparation (or revision) of a Site-Specific Welding Emissions Management Plan, in accordance with

**SECTION E. Source Group Restrictions.**

§63.11516(f)(7)(iii), "Requirements for opacities exceeding 20 percent."

(12) Site-Specific Welding Emissions Management Plan. If you have been required to prepare a plan in accordance with §63.11516(f)(7)(iii), "Site-Specific Welding Emissions Management Plan," you must maintain a copy of your current Site-Specific Welding Emissions Management Plan in your records and it must be readily available for inspector review.

(13) Manufacturer's instructions. If you comply with this subpart by operating any equipment according to manufacturer's instruction, you must keep these instructions readily available for inspector review.

(14) Welding Rod usage. If you operate a new or existing welding affected source which is not required to comply with the requirements of §63.11516(f)(3) through (8) because it uses less than 2,000 pounds per year of welding rod (on a rolling 12-month basis), you must maintain records demonstrating your welding rod usage on a rolling 12-month basis.

(15) Your records must be maintained according to the requirements in paragraphs (c)(14)(i) through (iii) of this section.

(i) Your records must be in a form suitable and readily available for expeditious review, according to §63.10(b)(1), "General Provisions." Where appropriate, the records may be maintained as electronic spreadsheets or as a database.

(ii) As specified in §63.10(b)(1), "General Provisions," you must keep each record for 5 years following the date of each occurrence, measurement, corrective action, report, or record.

(iii) You must keep each record on-site for at least 2 years after the date of each occurrence, measurement, corrective action, report, or record according to §63.10(b)(1), "General Provisions." You may keep the records off-site for the remaining 3 years.

§63.11520 [Reserved]

§63.11523 What General Provisions apply to this subpart?

The provisions in 40 CFR part 63, subpart A, applicable to sources subject to §63.11514(a) are specified in Table 2 of this subpart.

#### Regulatory Changes

Individual sources within this source group that are subject to 40 CFR Part 63 Subpart XXXXXX shall comply with all applicable requirements of the Subpart. 40 CFR 63.13(a) requires submission of copies of all requests, reports and other communications to both the Department and the EPA. The EPA copies shall be forwarded to:

Director  
Air Protection Division (3AP00)  
U.S. EPA Region III  
1650 Arch Street  
Philadelphia, PA 19103-2029

The Department copies shall be forwarded to:

Regional Air Program Manager  
PA Department of Environmental Protection  
909 Elmerton Avenue  
Harrisburg, PA 17110-8200

In the event that the Federal Subpart that is the subject of this Source Group is revised, the permittee shall comply with the revised version of the subpart, and shall not be required to comply with any provisions in this permit designated as having the subpart as their authority, to the extent that such permit provisions would be inconsistent with the applicable provisions of the revised subpart.



**SECTION F. Alternative Operation Requirements.**

No Alternative Operations exist for this State Only facility.



**SECTION G. Emission Restriction Summary.**

No emission restrictions listed in this section of the permit.

**SECTION H. Miscellaneous.**

This operating permit supersedes the previous operating permit for this facility.

The following sources are not subject to any specific work practice standards, testing, monitoring, recordkeeping or reporting requirements:

- Diesel fuel, stored in a 575 gallon tank, used for the operation of a railroad switch engine and yard truck vehicles.
- Gasoline stored in a 300 gallon tank used for facility vehicles.
- The use of a propylene torch for the minor repairs of various metallic parts.
- Emissions from the waste water treatment plant in the treatment of water and caustic solution generated by the steam injection process involved with the purging of the tank cars.
- The use of a liquid bath in the inspection for surface cracks and imperfections on various steel parts for the railroad cars.
- The use of various portable electrical bench top and air powered grinding units.
- Ninety-six (96) natural gas fired space heaters.
- Hydraulic Riveters
- Drill Press (utilizing cooling oils)
- Chop saw (utilizing cooling oils)

Source ID, FM003, Purged Flare Feed, consists of the following fuels:

- Propane
- Butane
- Butadiene (inhibited)
- Butylene
- Isobutane
- Isobutylene
- Propylene
- Propane Propylene (mixture of propane and propylene)
- Anhydrous Ammonia

The Source ID 108 MACT Subpart 6X activities include the following:

- Existing Dry Abrasive Blasting (Source ID 105)
- New Welding Operations
- Existing Spray Painting (Source IDs 101 & 102)
- New Pipe Bender Machining Operations
- New Coating Booth (Source ID 109)

This permit is derived from information taken from Operating Permits:

07-399-005  
07-302-024  
07-399-002;

and Plan Approval:  
07-05727A

Applicable requirements from General Permit GP1-07-05027A are incorporated under Source ID 034.

This Permit is Revision No. 2 of the facility's State Only Permit issued on September 27, 2021. This revision incorporates the requirements of Plan Approval 07-05027B.



\*\*\*\*\* End of Report \*\*\*\*\*

---